

16743-1

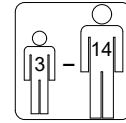

www.plus.dk



Max
140 kg

Senest revideret Dec. 2017

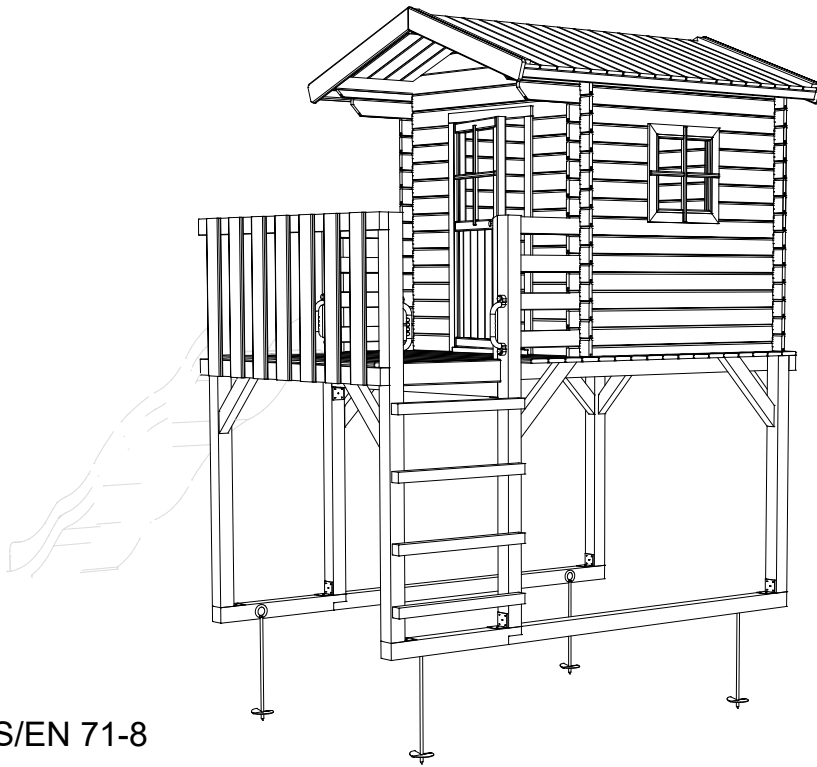

CE DS/EN 71-8

Advarsel. Kun til privat brug.
Warnung. Nur für privaten Gebrauch.
Varning. Endast för privat bruk.
Warning. Only for domestic use.

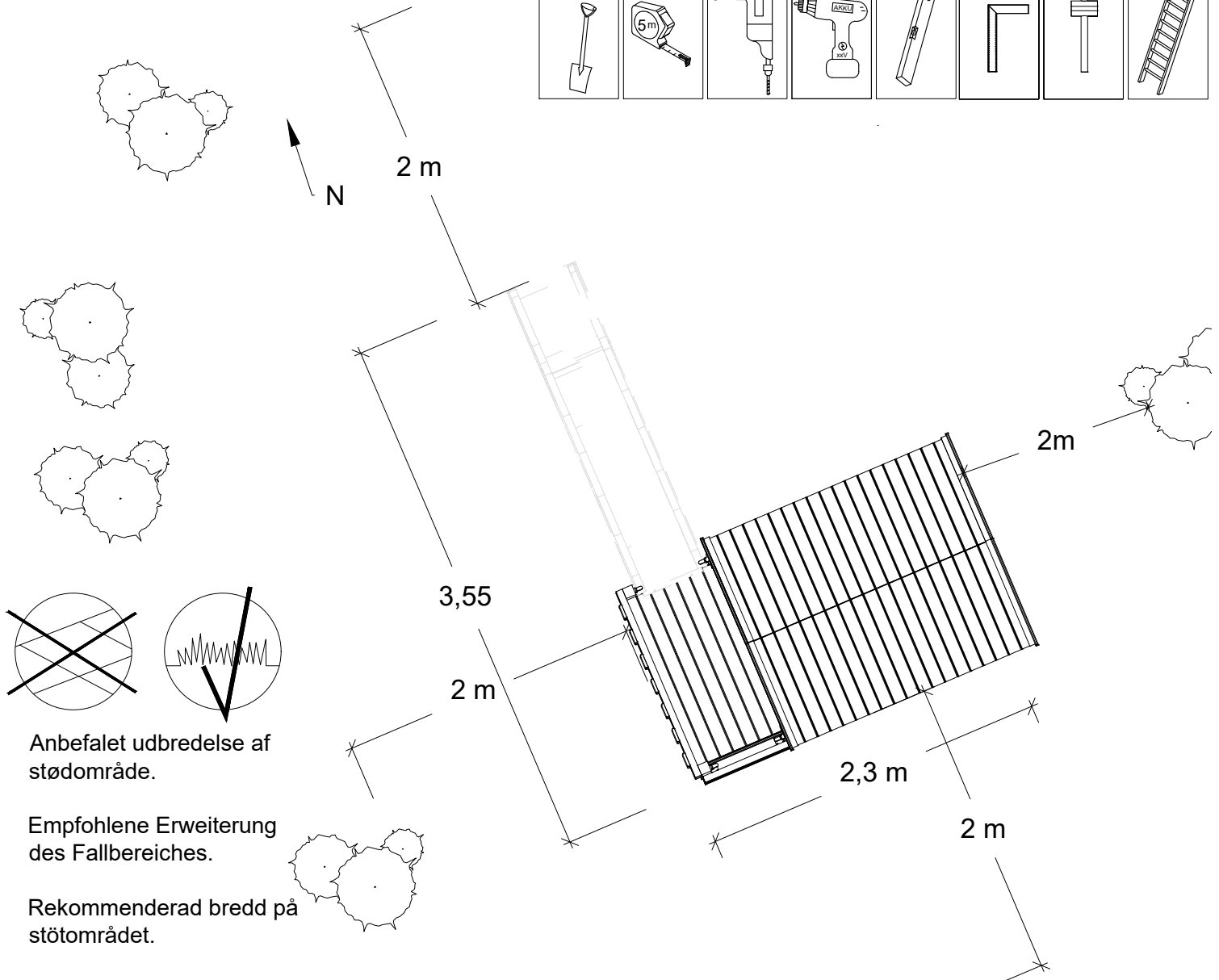
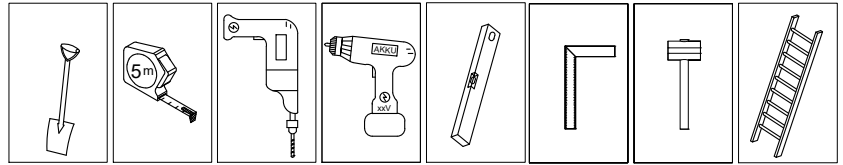

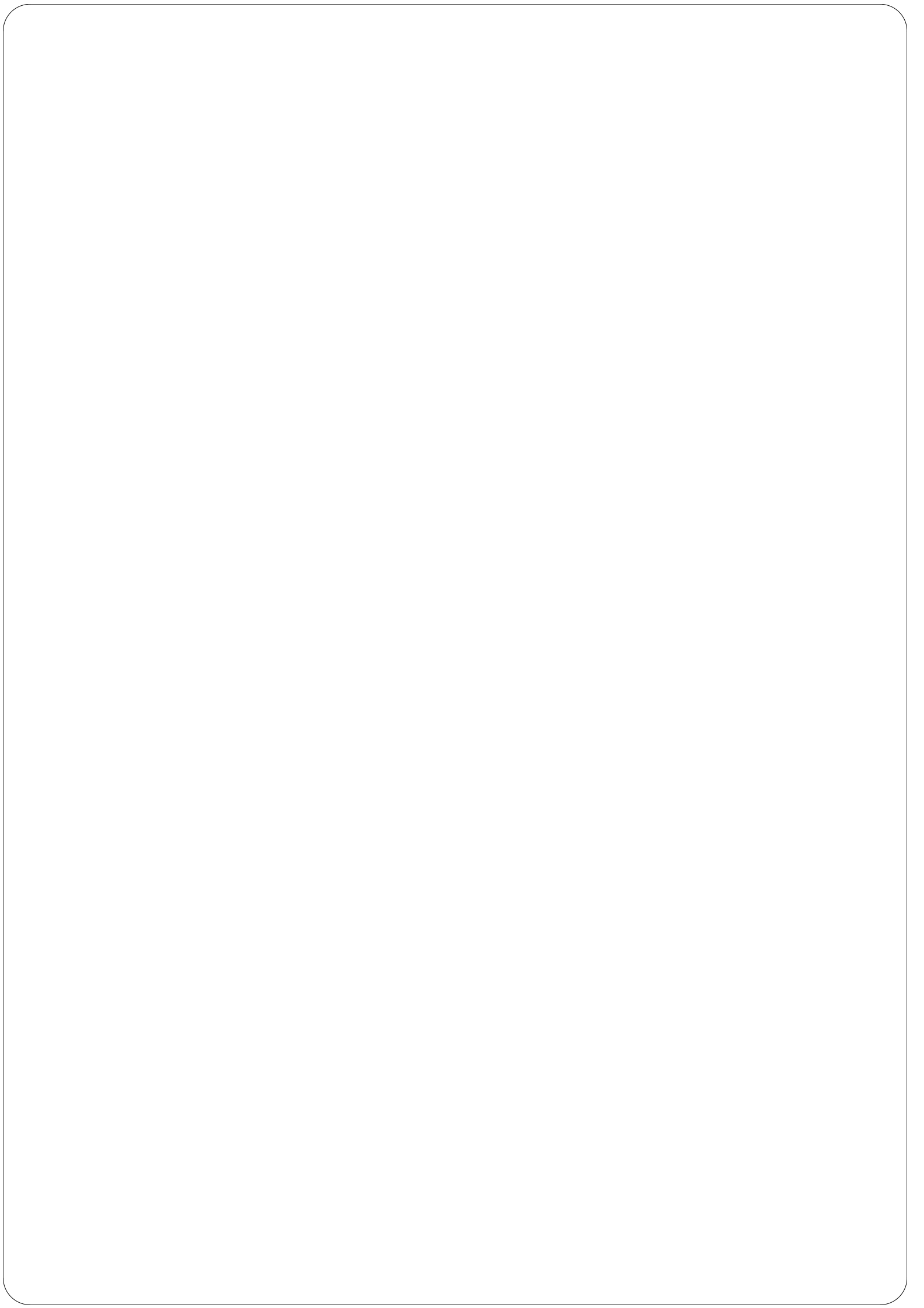

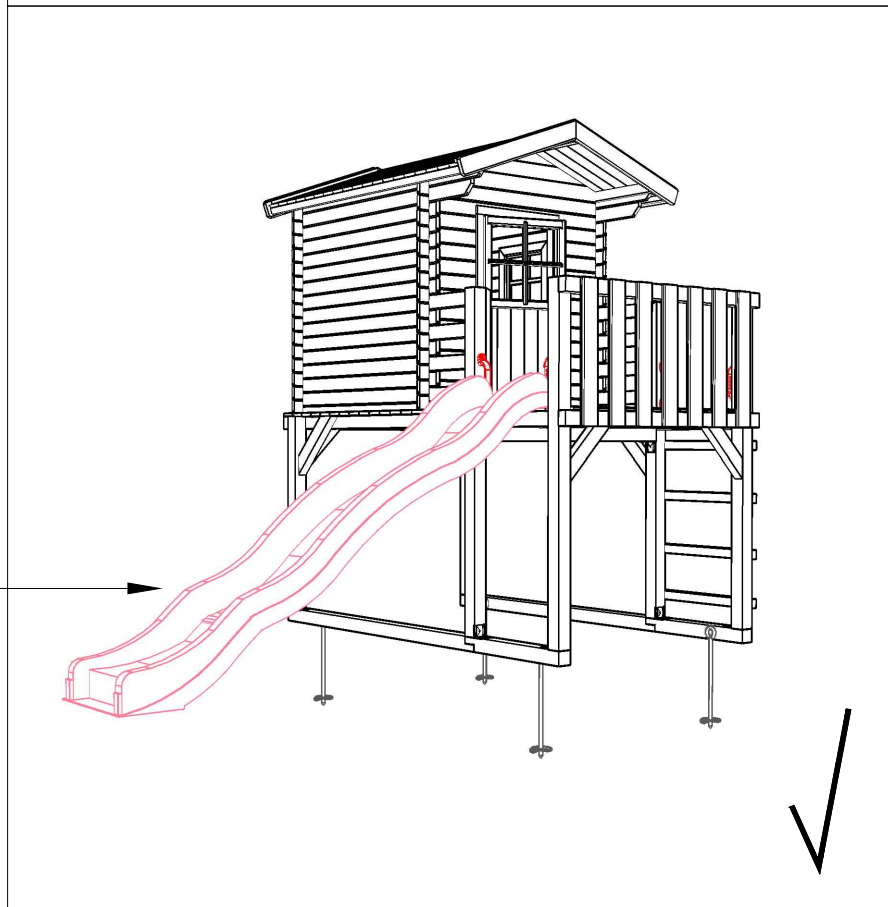
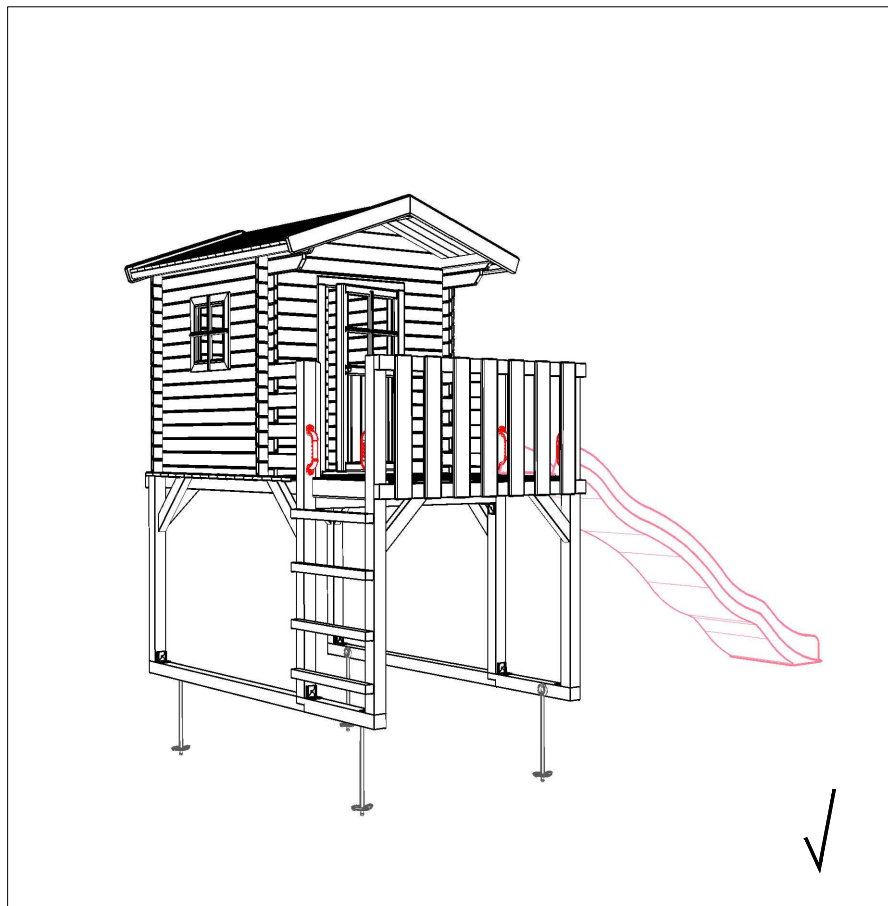

DK: Medfølger ikke !
D:Nicht im Lieferumfang
enthalten.
S:Medfølger ej!

Læs denne vejledning grundigt igennem.
Lesen Sie diese Anleitung sorgfältig durch.
Läs denna bruksanvisning noga.

Placering af legehus på ben.

Konstruktionen skal placeres frit, så der mindst er 2 m til nærmeste høje forhindring, som f.eks. gyngestativ, redskabsrum, træer og lignende man kan kravle over på, se forside.

Underlaget under huset bør overholde kravene til støddæmpning.

Græs har udmærkede støddæmpende egenskaber, hvis det vedligeholdes ordentligt med grønt, trimmet og godt rodnet.

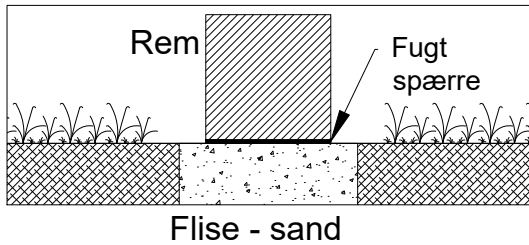

Remmene anbringes så de ligger plant, på et punktfundament f.eks. fliser - sand og med en fugt spærre f.eks. tag pap.

Vigtigt - der skal gøres plades for montage af jordankre. Se side 4.

Vi anbefaler at der forbores, for at undgå at træet revner.

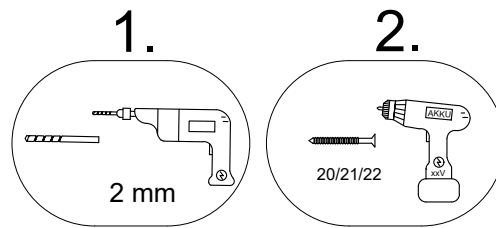

Vedligeholdelse:

Legehuset og terrassen er ved leveringen ubehandlet og **skal** derfor efterbehandles.

For efterbehandlig se www.plus.dk - Behandling og vedligehold

Tagkonstruktionen bør af hensyn til holdbarhed og sikkerhed beklædes med tagpap. *Medfølger ikke.*



Vigtigt - hold øje med at legehuset er i orden.

Kontroller jævnligt og mindst hver 6 måned legehuset:

- Løse skruer efterspændes.
- Bevægelige dele skal olieres.
- Skulle der være defekte dele i selve konstruktionen repareres/ udskiftes disse, ligesom taget skal være intakt.
- Vedligeholdelse af støddabsorberende underlag.

Venligst bemærk:

at egenskaber og karakteristika, som er typiske for det naturmateriale, som træ er, ikke kan give anledning til reklamation:

- Revnedannelse i overfladen
- Harpikslommer / harpiksudtræk
- Knasthuller er også en naturlig bestanddel i træ. Små knastudfald kan fyldes med en egnet spartelmasse.

Ovennævnte reducerer ikke træets kvalitet og berettiger derfor heller ikke til reklamation.

Gem denne vejledning til senere brug.

A

Platzierung des Kinderspielhauses:

Das Kinderspielhaus sollte mit einem Sicherheitsabstand von 2 Metern zu anderen Hindernissen, wie z. Bsp. Gebäuden, Bäumen, Schaukeln und Zaunanlagen platziert werden. Die Stellfläche sollte eben und fest sein.

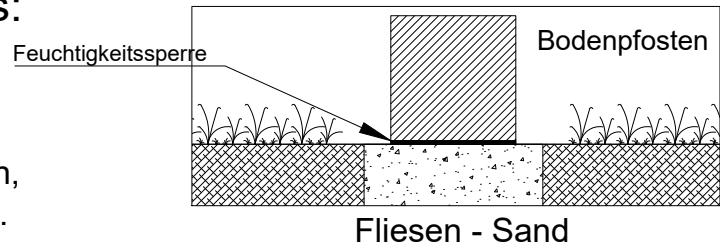

Die mitgelieferten druckimprägnierten Bodenpfosten müssen so angebracht werden, dass die in Waage liegen. Hier muss ein Punktfundament mit Fliesen o. Sand und mit einer Feuchtigkeitssperre (z. B. Dachpappe) verlegt werden.

WICHTIG – es muss Platz für die Montage der mitgelieferten Erdanker vorhanden sein (siehe Seite 4)

B

Wir empfehlen das Vorbohren der Löcher, um Risse im Holz zu vermeiden.

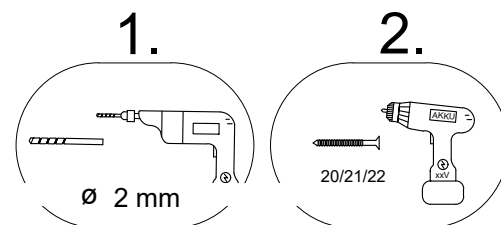

C

Bitte beachten:

Die Dachkonstruktion sollte in Bezug auf Haltbarkeit und Sicherheit mit Dachpappe bekleidet werden. Nicht im Lieferumfang enthalten.

Pflegeanleitung:

Das Kinderspielhaus ist bei der Lieferung unbehandelt und sollte direkt nach der Montage nachbehandelt werden.

Wir empfehlen das Haus mit einer Holzschutzlasur zu imprägnieren. Diese Lasur sollte der DIN EN 71 entsprechen und für Kinderartikel freigegeben sein. Fragen Sie Ihren Fachhändler nach einem geeigneten Holzöl.

Die Grundkonstruktion ist in regelmäßigen Abständen auf etwaige Beschädigungen und Fäulnisbefall zu kontrollieren.

Die Schraubverbindungen sind ebenso in regelmäßigen Abständen auf festen Sitz und Stabilität zu überprüfen. Bei Bedarf sind diese nachzuziehen.

Holz ist ein Naturprodukt, welches arbeitet und sich im Laufe der Zeit verändert. Durch die unterschiedlichen klimatischen Bedingungen während des Jahres kann es zu Rissbildungen in der Oberfläche kommen. Harzaustretungen und Astlöcher können vorkommen. Diese Vorkommnisse reduzieren nicht die Qualität des Holzes und berechtigen deshalb nicht zur Reklamation

Aufbewahren Sie diese Montageanleitung für einen eventuell späteren Gebrauch

A

Placering av lekstuga.

Lekstugan ska placeras fritt med minst 2 m till närmsta höga hinder som det går att klättra upp på, t.ex. gungställning, redskapsbod, träd, staket och liknande.

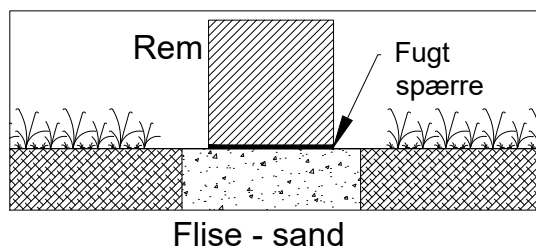

Placera lekstugan på ett plant underlag, på punktfundament, t.ex. flisor, och med en fuktspärr mellan flisor och bottenribbor. Se sidan 4 för montering af förankring.

B

Vi rekommenderar förborring för att undvika sprickbildning i träet.

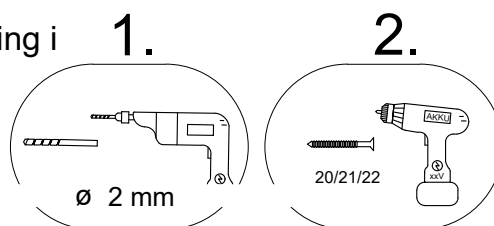

C

OBS:

Takkonstruktionen bör av hänsyn till hållbarhet och säkerhet täckas med takpapp. Medföljer ej.

Underhåll:

Lekstugan är vid leverans obehandlad och bör därför efterbehandlas.

Vi rekommenderar att nedanstående efterbehandling utförs strax efter uppställning.

1. Produkten rengörs/rensas och grundbehandlas med träolja innehållande fungicider som tränger in i träet och ger ett effektivt skydd mot röta och svampangrepp. Inom 14 dagar ska produkten ytbehandlas med önskad färg. Målade ytor bör ses efter och rengöras regelbundet. På så sätt avlägsnas sporer och näringsämnen från ytan, tillväxt av mögel och alger förebyggs och förlänger behandlingens livstid.

Kontrollera lekstugan med jämna mellanrum och minst var sjätte månad:

- Lösa skruvar dras åt.
- Om det finns defekta delar i själva konstruktionen ska dessa repareras.
- Taket ska vara intakt.

Observera:

att egenskaper och karakteristika som är typiska för det naturmaterial som trä är, inte är orsak till reklamation:

- Sprickbildning i ytan
- Kåda

Kvisthål är också en naturlig beståndsdel i trä. Små kvisthål kan fyllas med en därtill lämpad spackelmassa.

Ovannämnda minskar inte trädets kvalitet och berättigar därför heller inte till reklamation.

Spar dessa instruktioner för senare bruk.

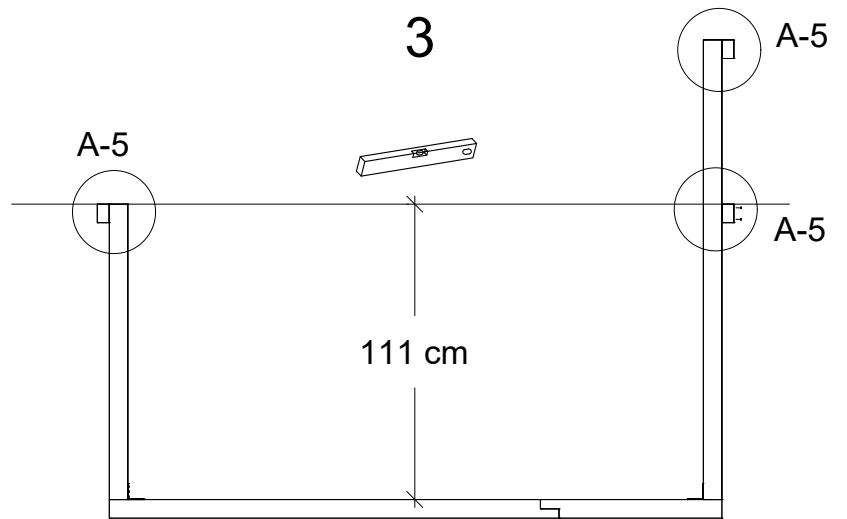
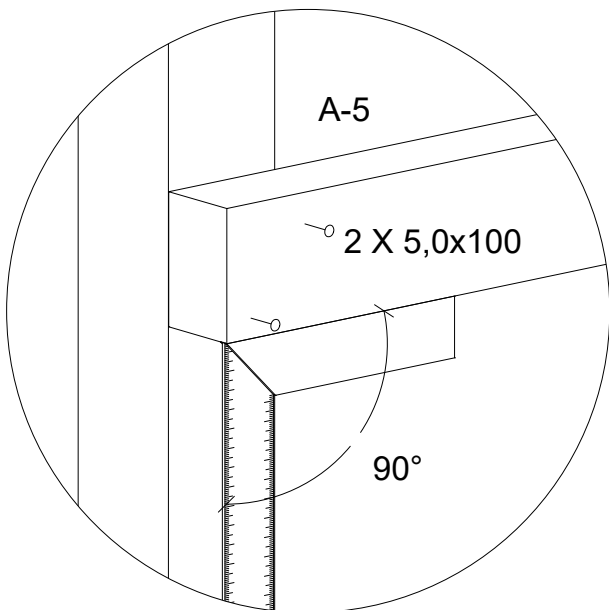
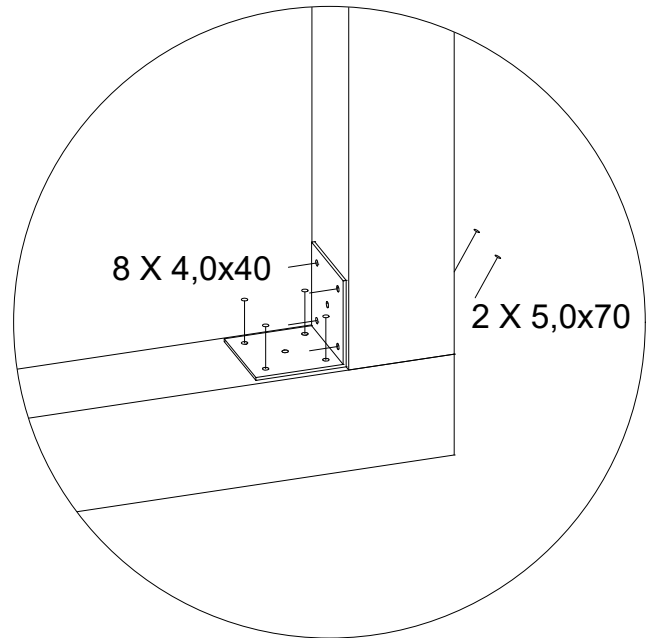
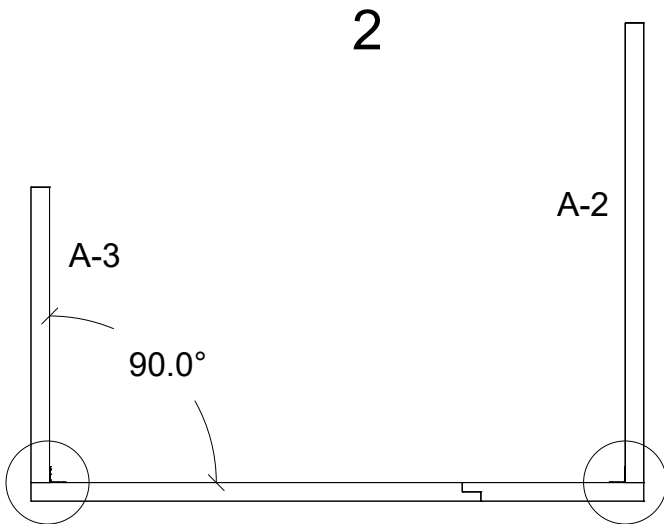
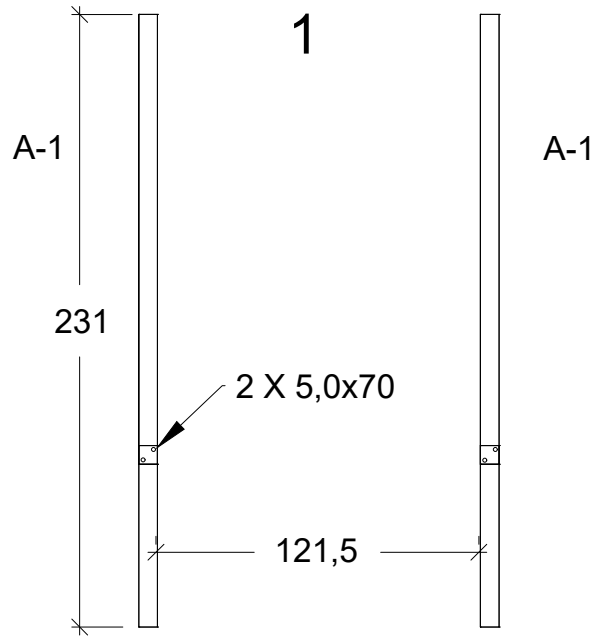
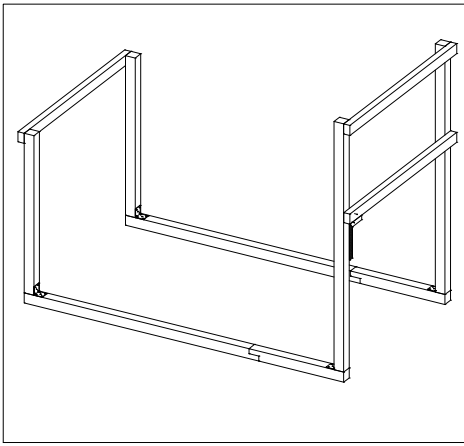

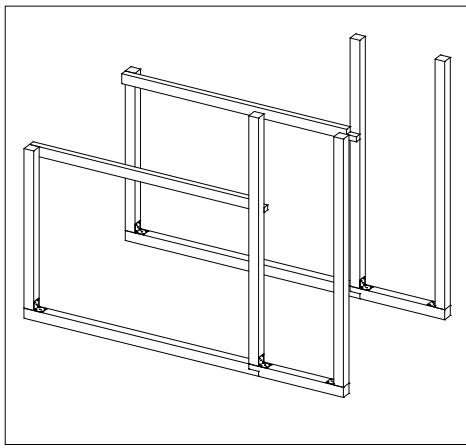

4

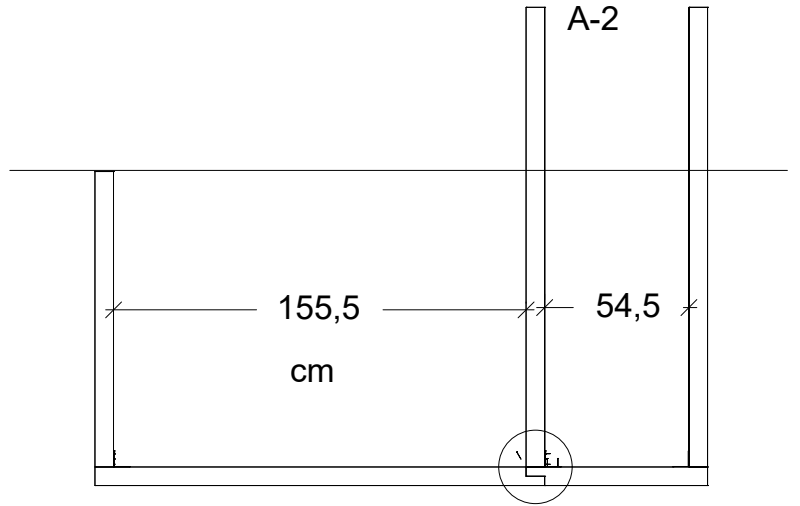

5

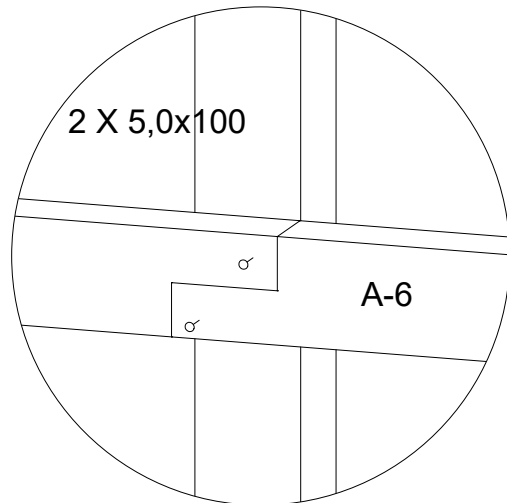
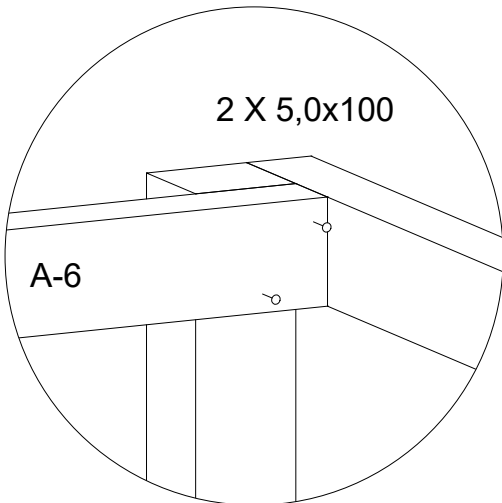
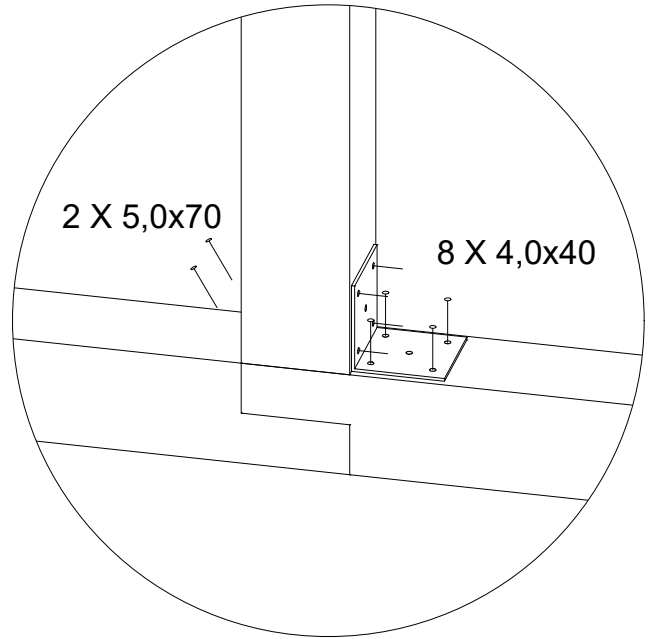
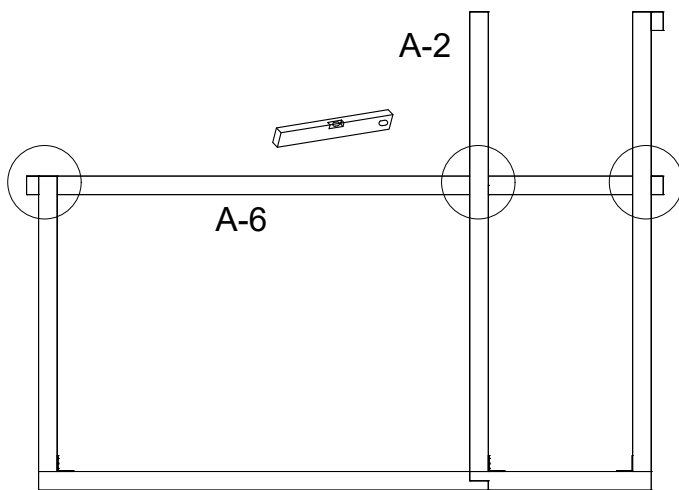

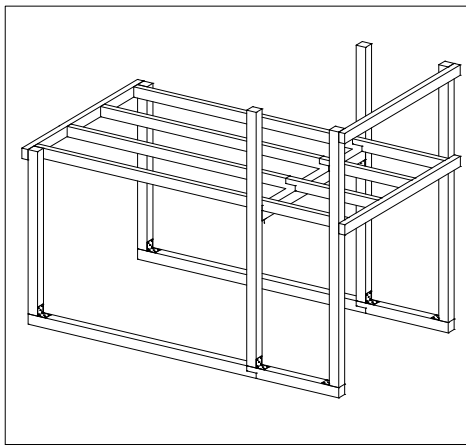

6

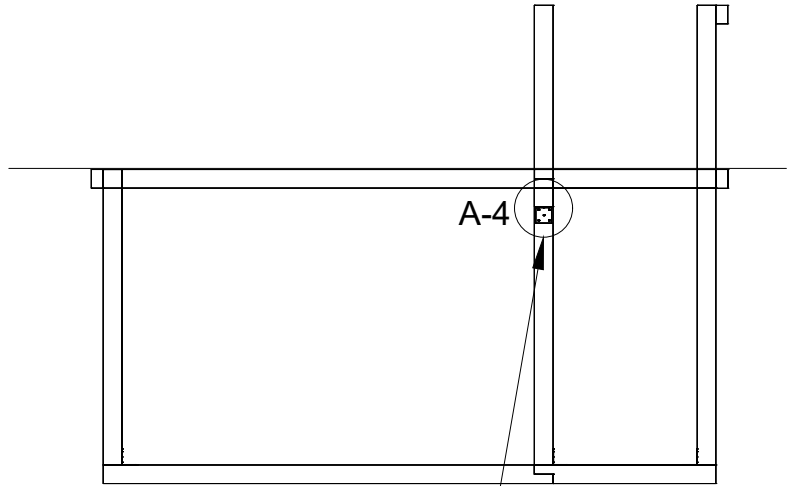

7

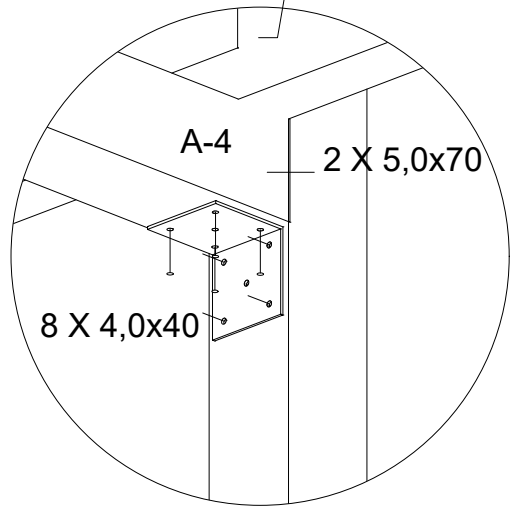
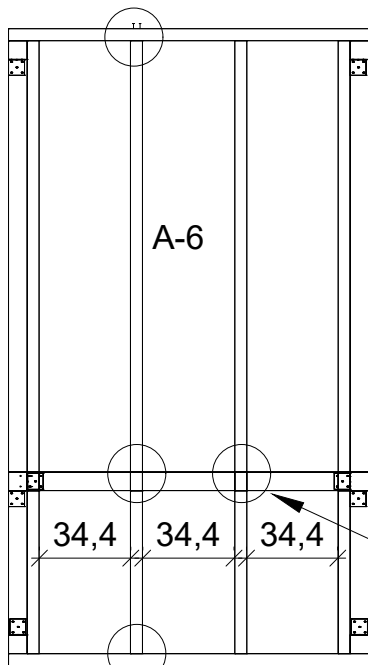

8 X 4,0x40

cm

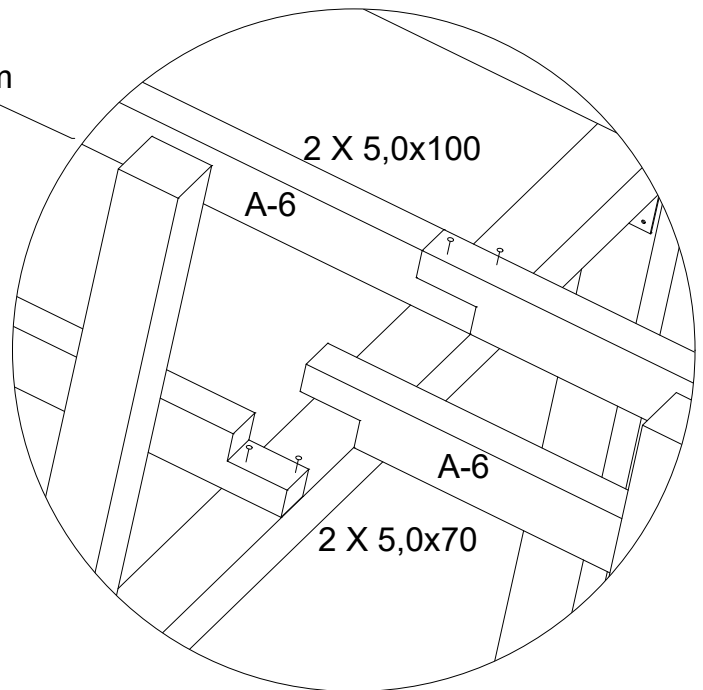

2 X 5,0x100

A-6

A-6

2 X 5,0x70

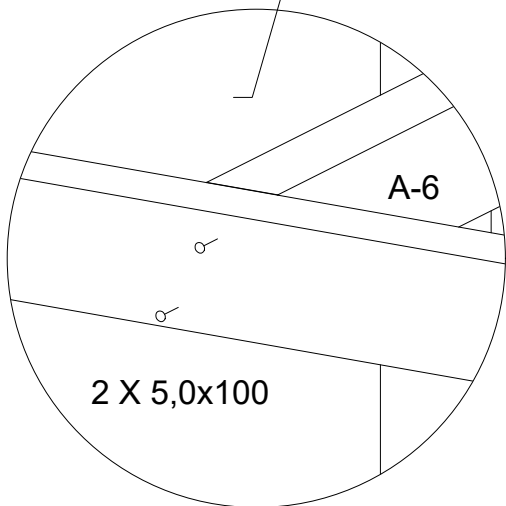

A-6

2 X 5,0x100

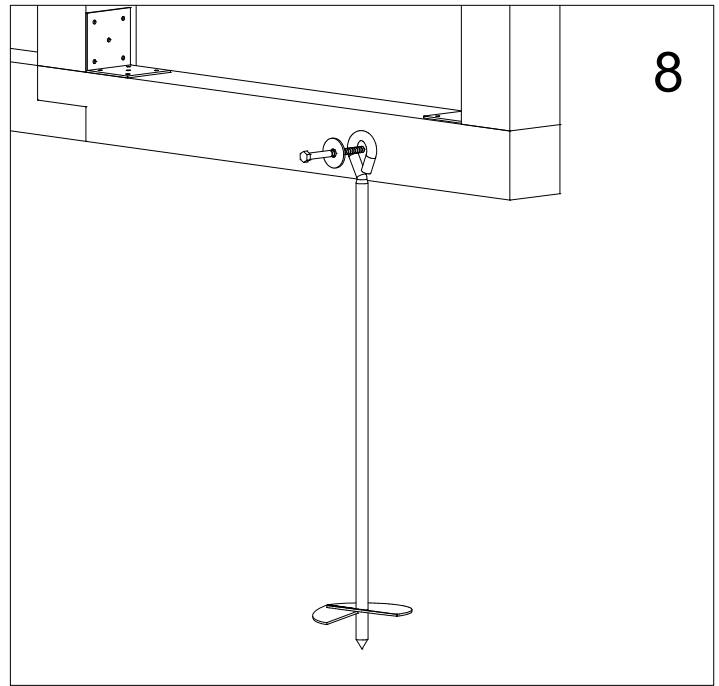
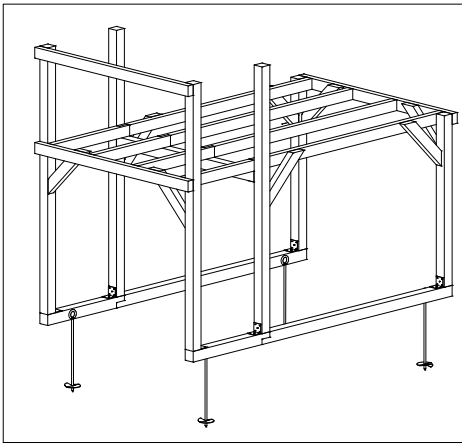

DK: Jordankret drejes ned i jorden, jorden skal have en sådan struktur, at man ikke kan trække jordankret op igen.

Når jordankret er i jorden fastgøres det til stolpen. Kontrollere jævnligt at jordankrene er ordenligt i jorden og fastgjort til stolpe.

D: Die Erdanker in die Erde drehen und an den Pfosten befestigen.

Die Erde muss so beschaffen sein, dass es nicht möglich ist die Erdanker aus der Erde zu ziehen. Die Erdanker regelmäßig kontrollieren.

S: Jordankaret vrids ned i jorden, som ska vara av sådan struktur att jordankaret inte kan dras upp igen.

När jordankaret sitter ordenligt fästs det vid stolpen. Kontrollera regelbundet att jordankarna sitter fast ordenligt i både mark och stolpe.

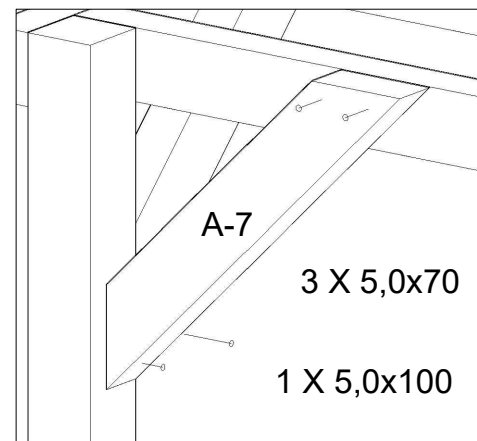
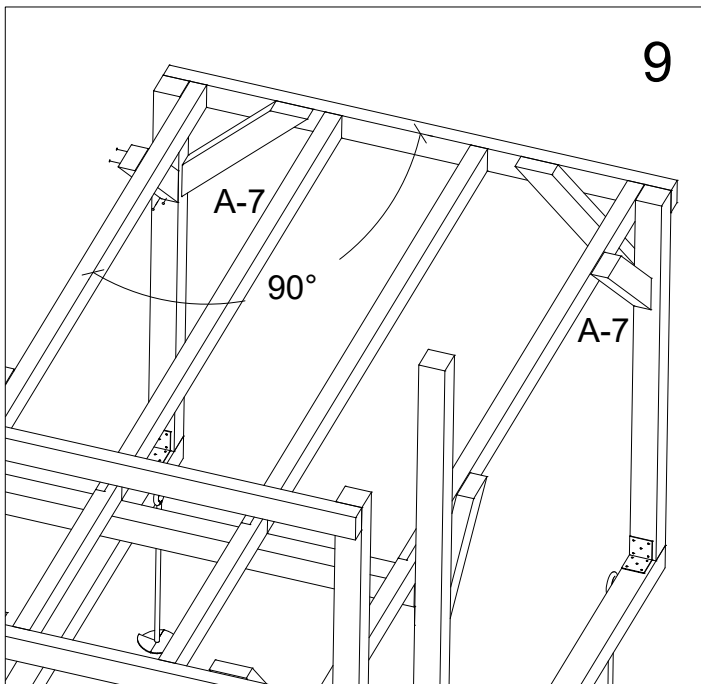

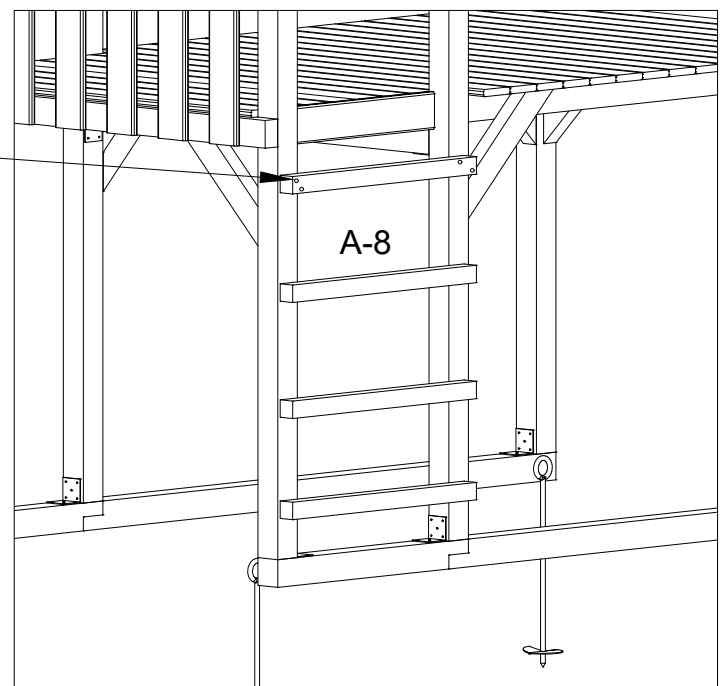
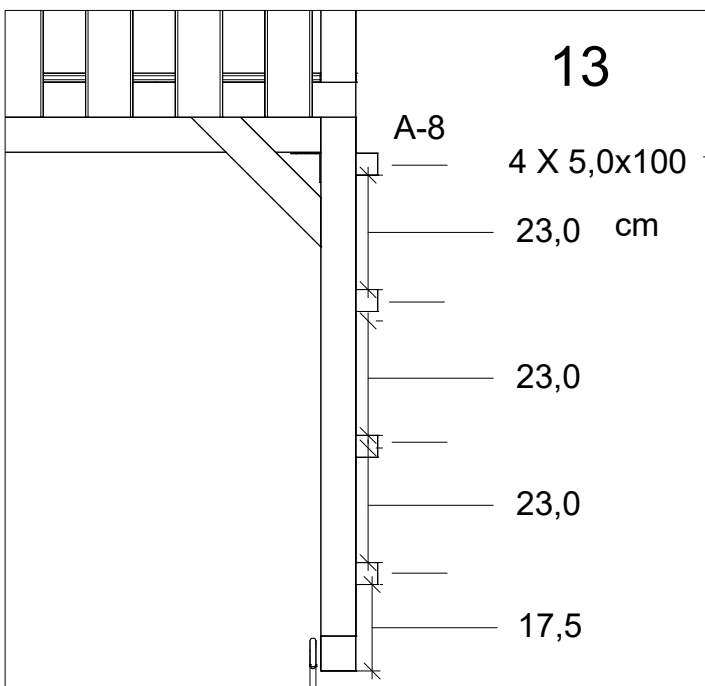
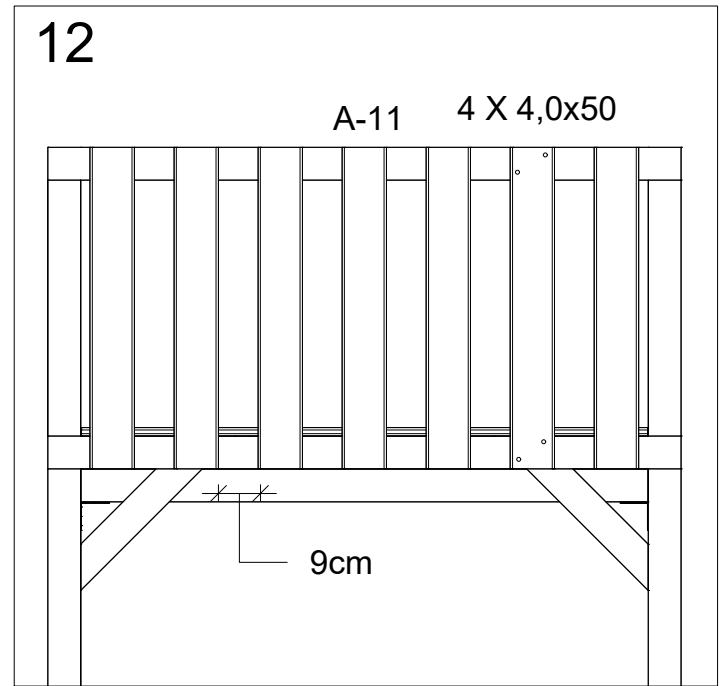
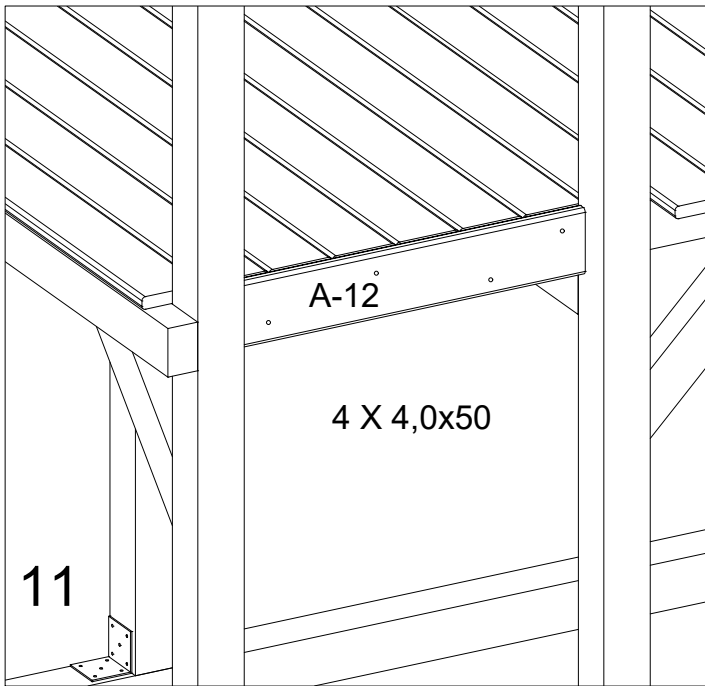
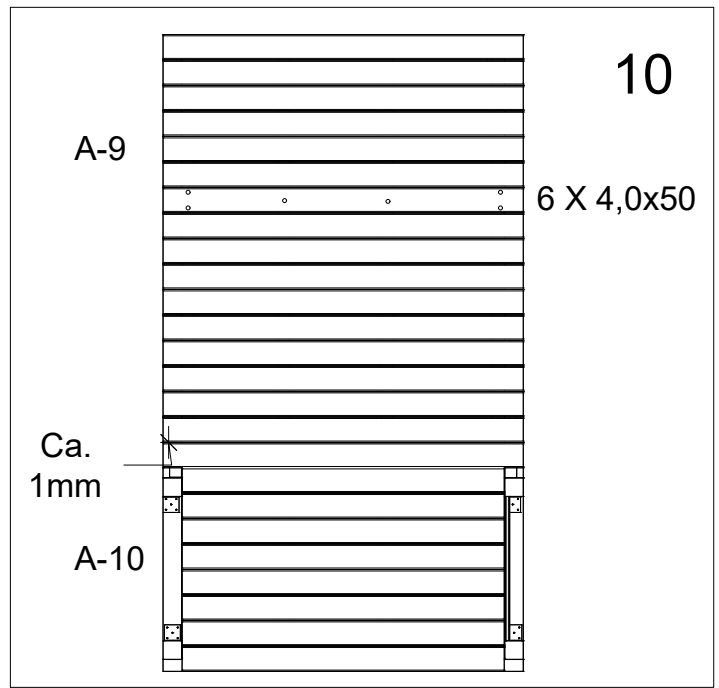
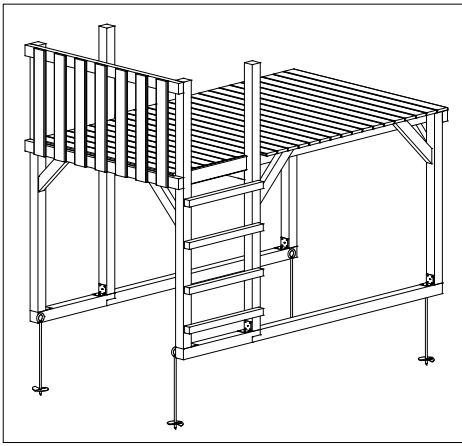

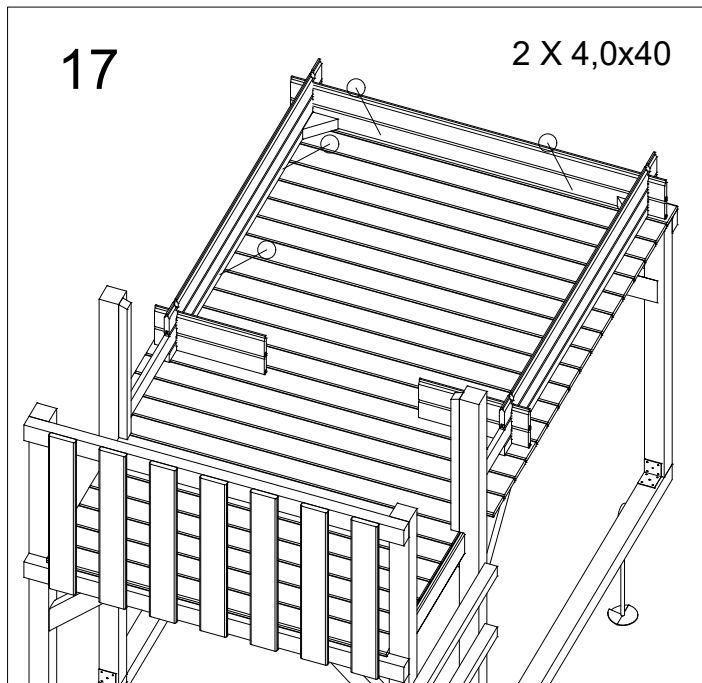
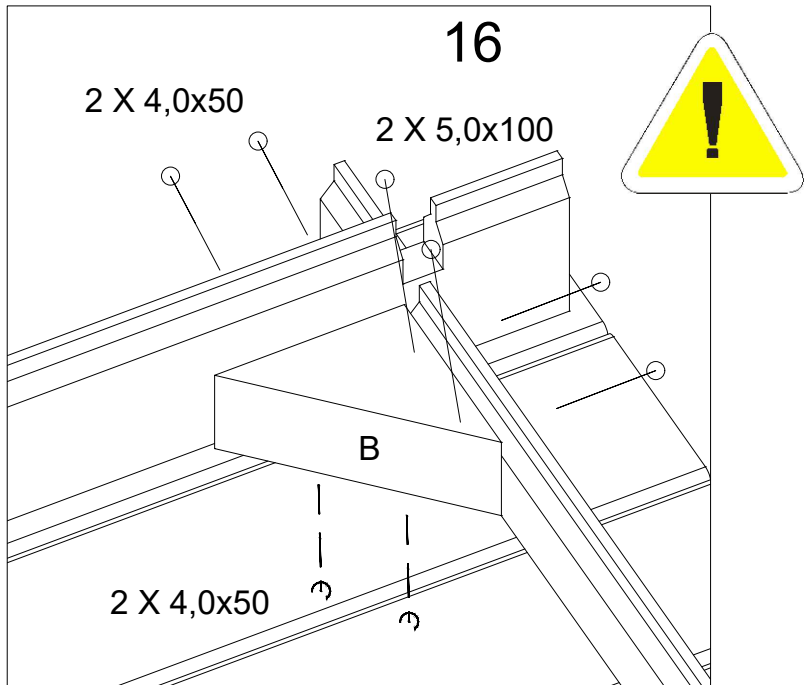
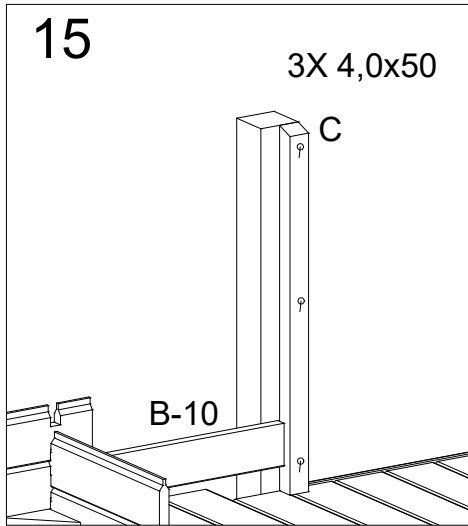
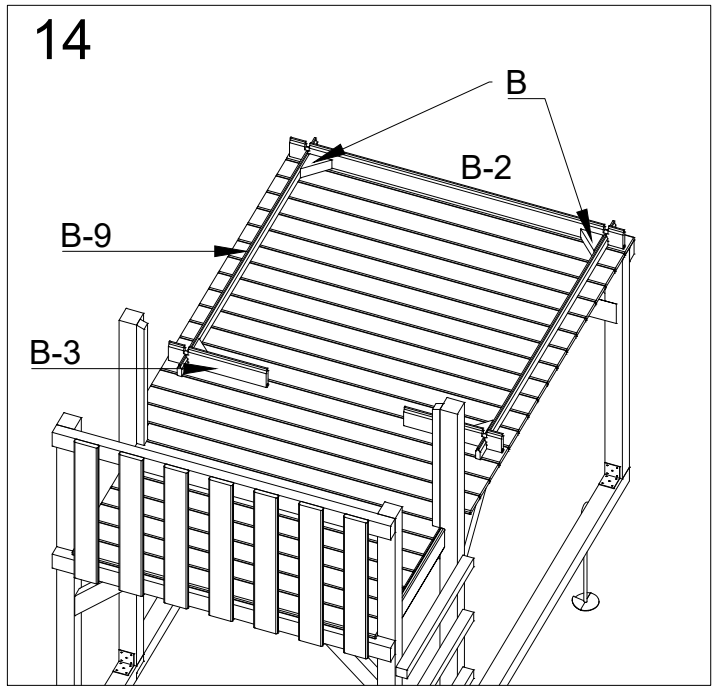
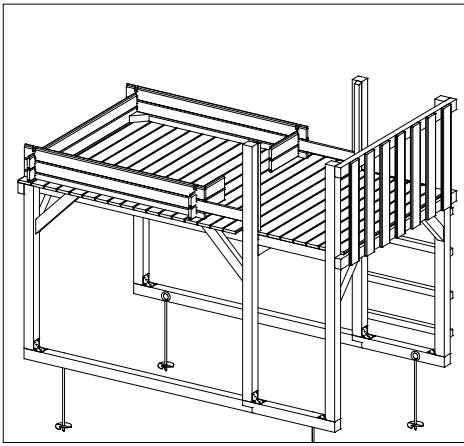

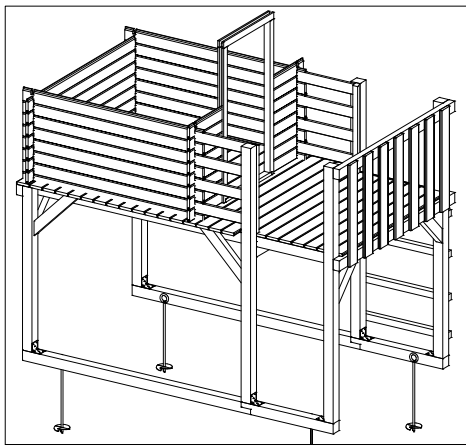

18

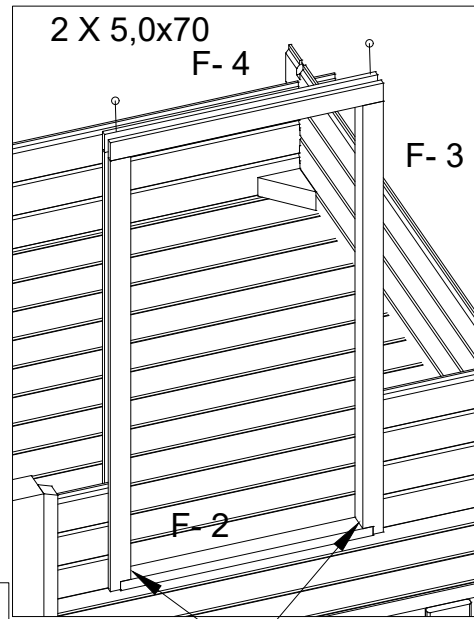

19

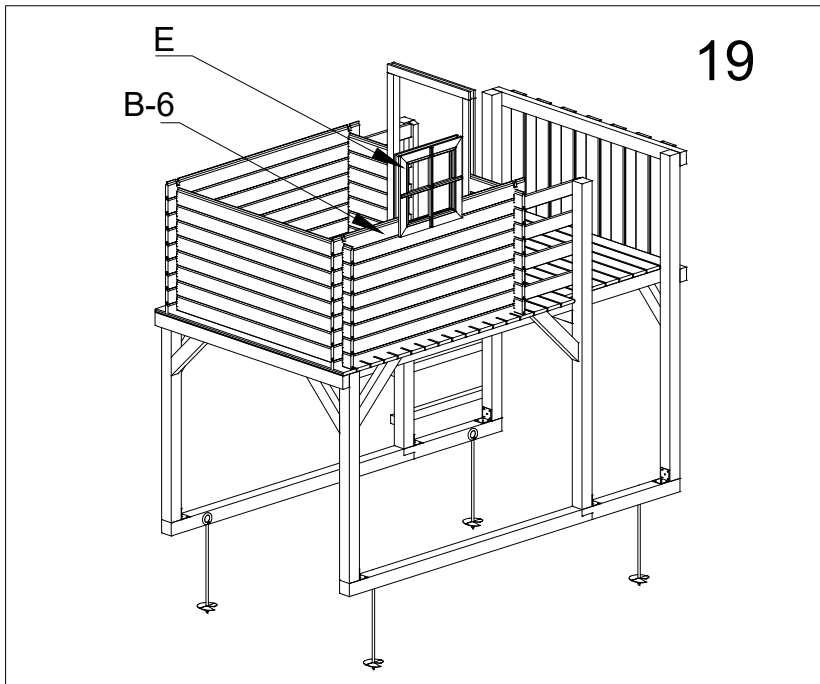

2 X 4,0x50

21

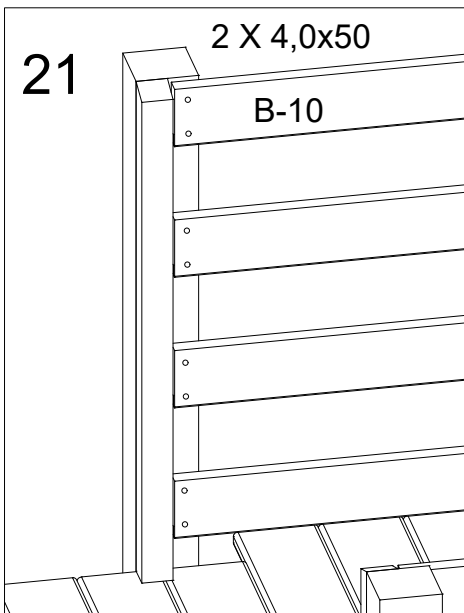

20

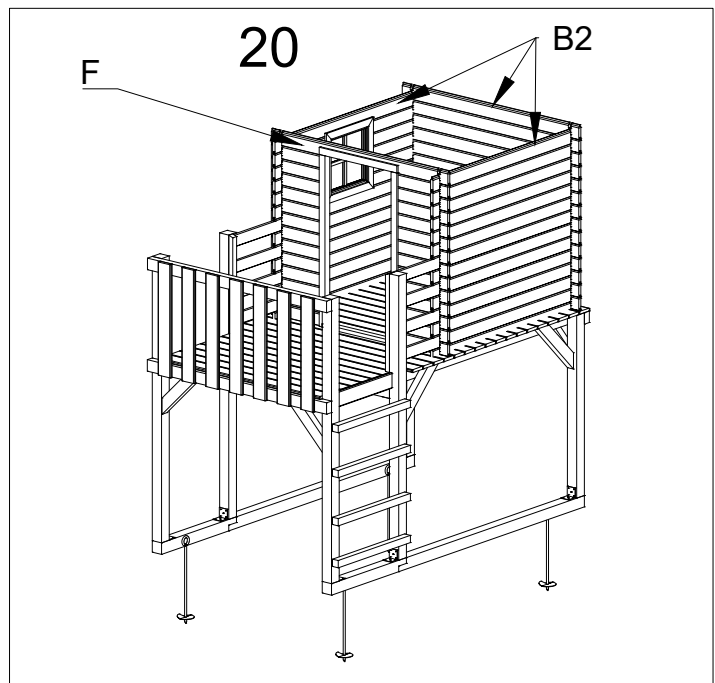

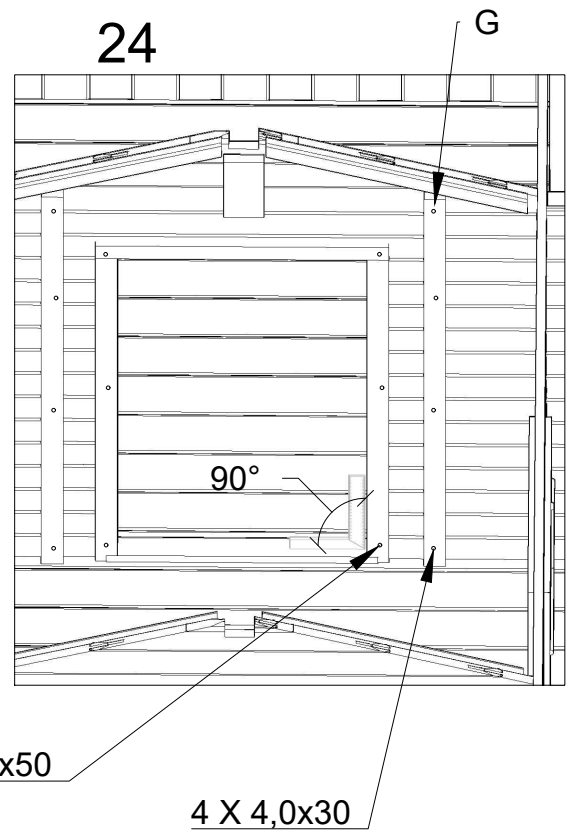
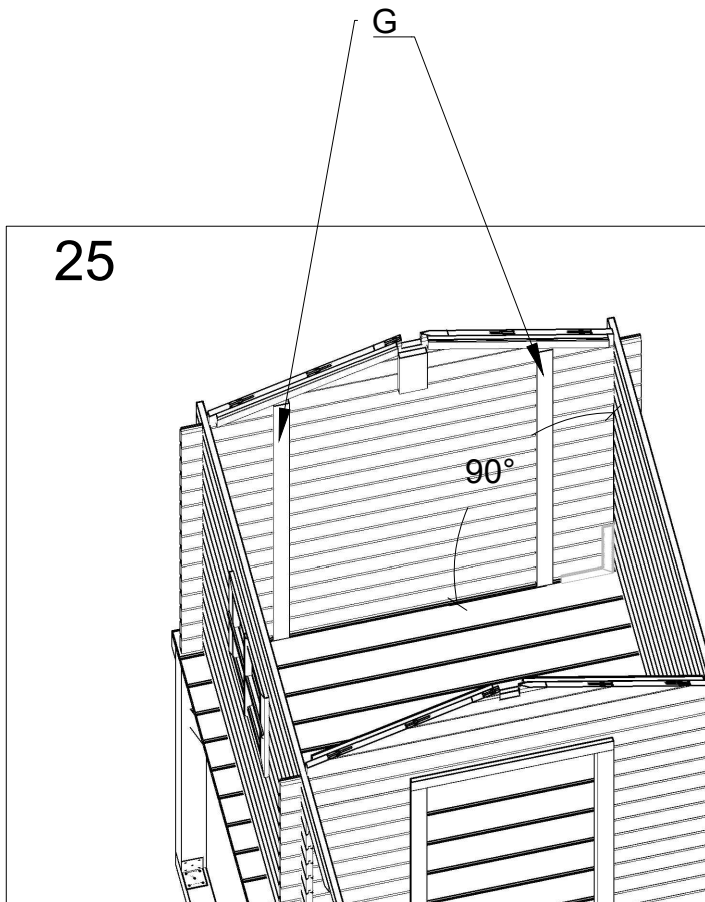
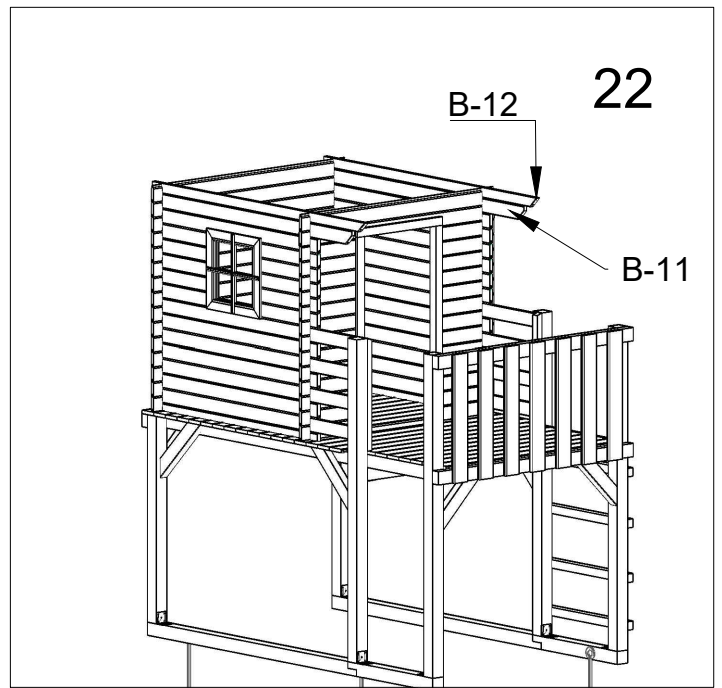
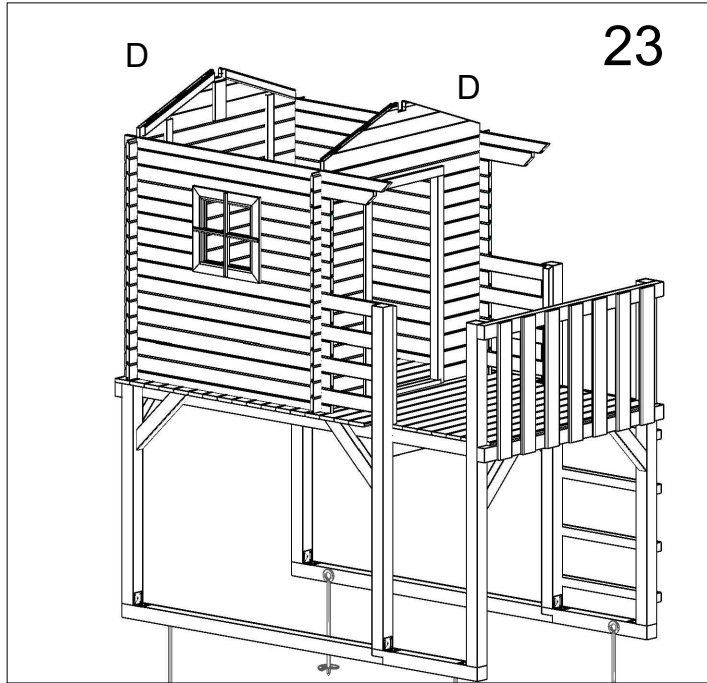

26

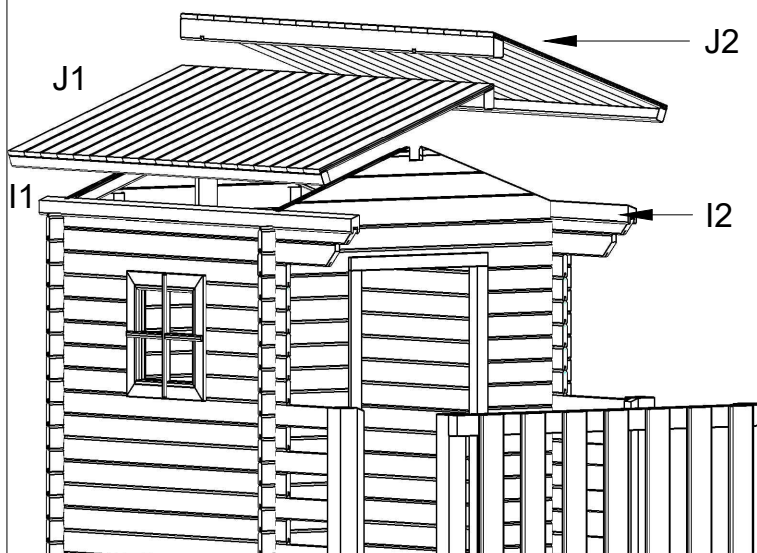

27

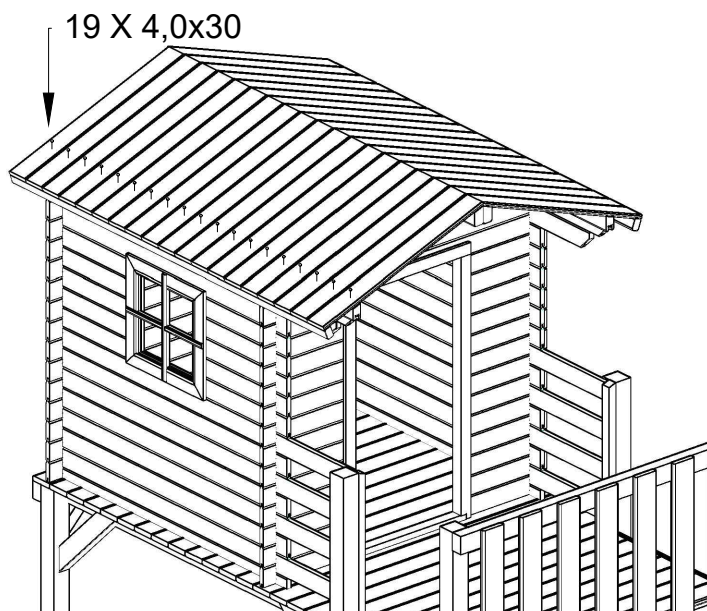

28

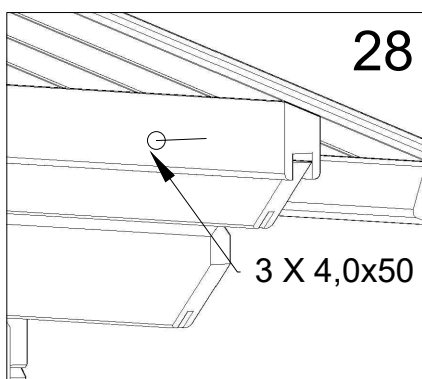

29

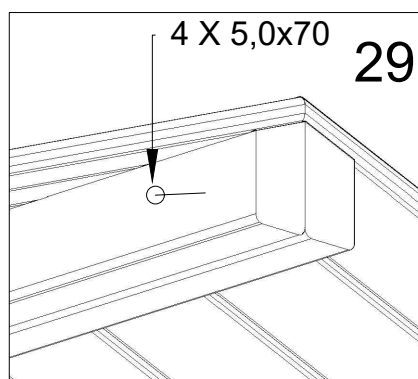

31

3 x 4,0x30

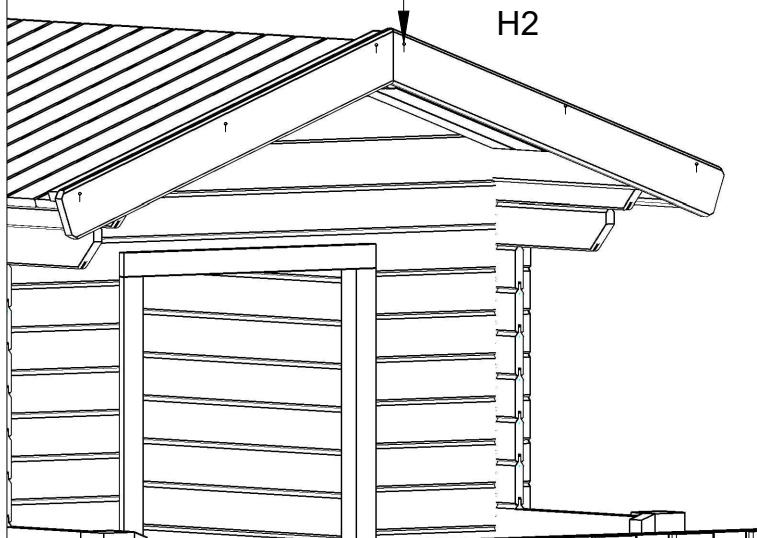

30

3 X 4,0x30

H1

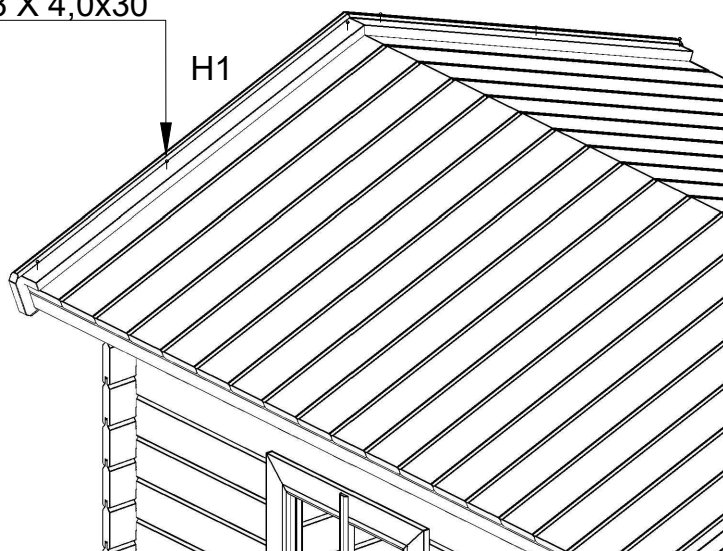

Tagkonstruktionen bør af hensyn til holdbarhed og sikkerhed beklædes med tagpap. Medfølger ikke.

Die Dachkonstruktion sollte in Bezug auf Haltbarkeit und Sicherheit mit Dachpappe bekleidet werden. Nicht im Lieferumfang enthalten.

Takkonstruktionen bör av hänsyn till hållbarhet och säkerhet täckas med takpapp. Medföljer ej.

Bitte beachten:

32

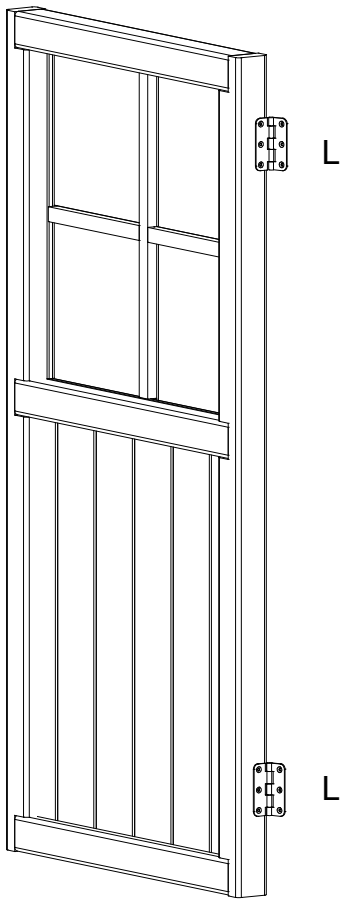

33

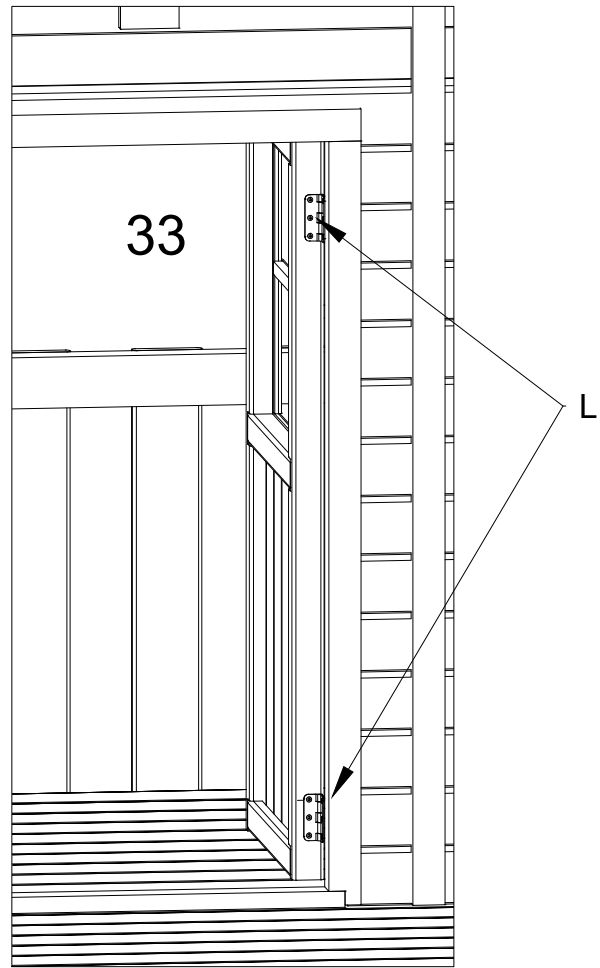

34

F-5

4 X 4,0x50

K-2

K-1

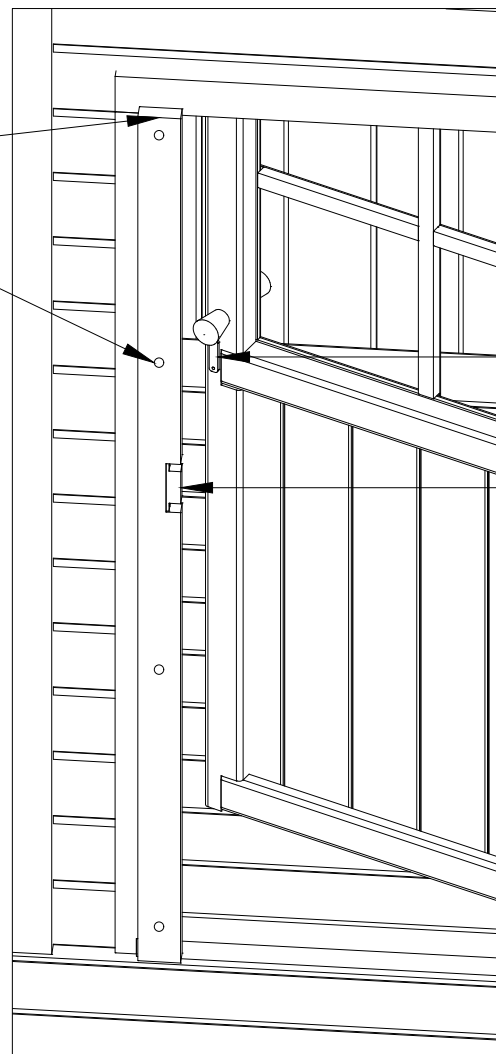





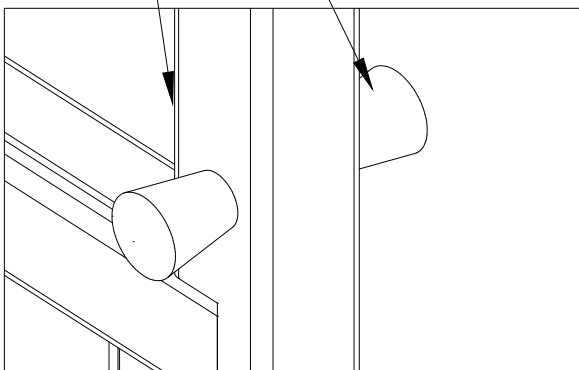

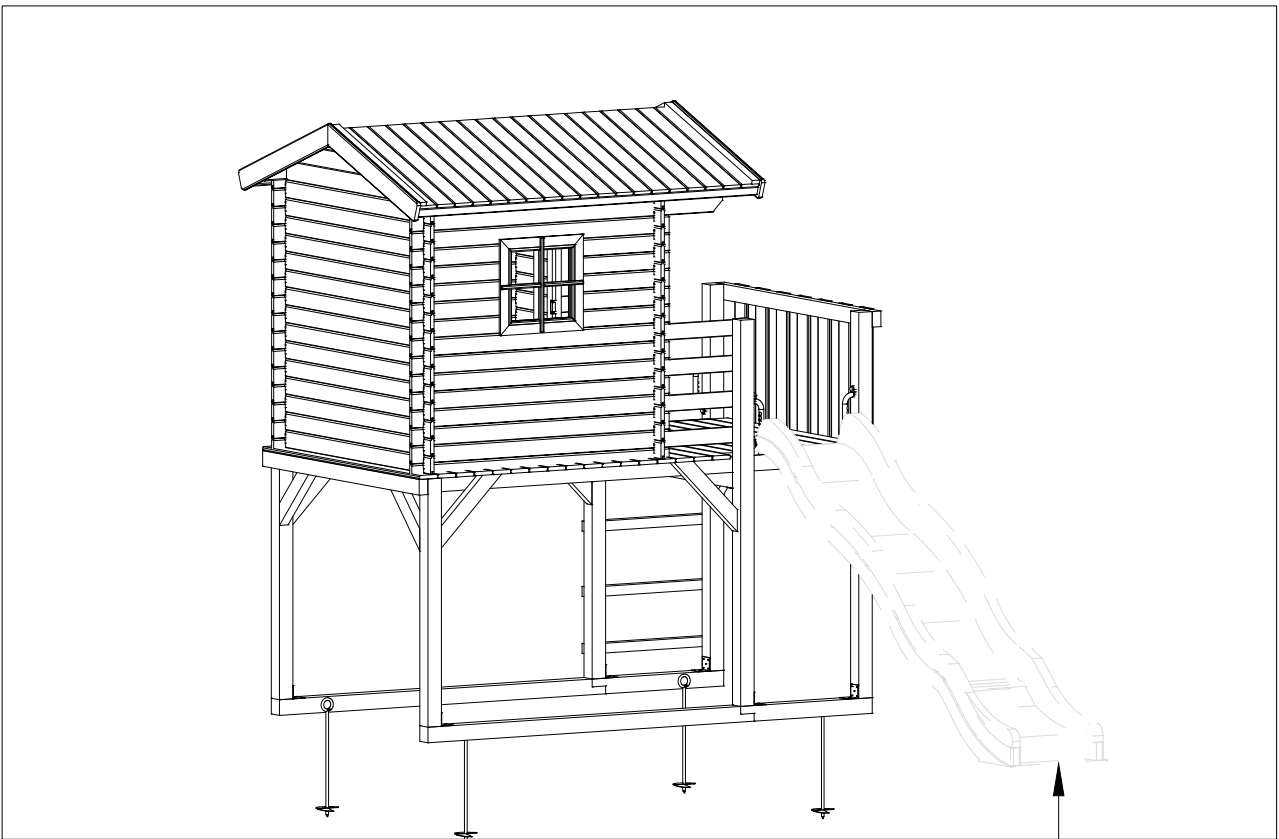
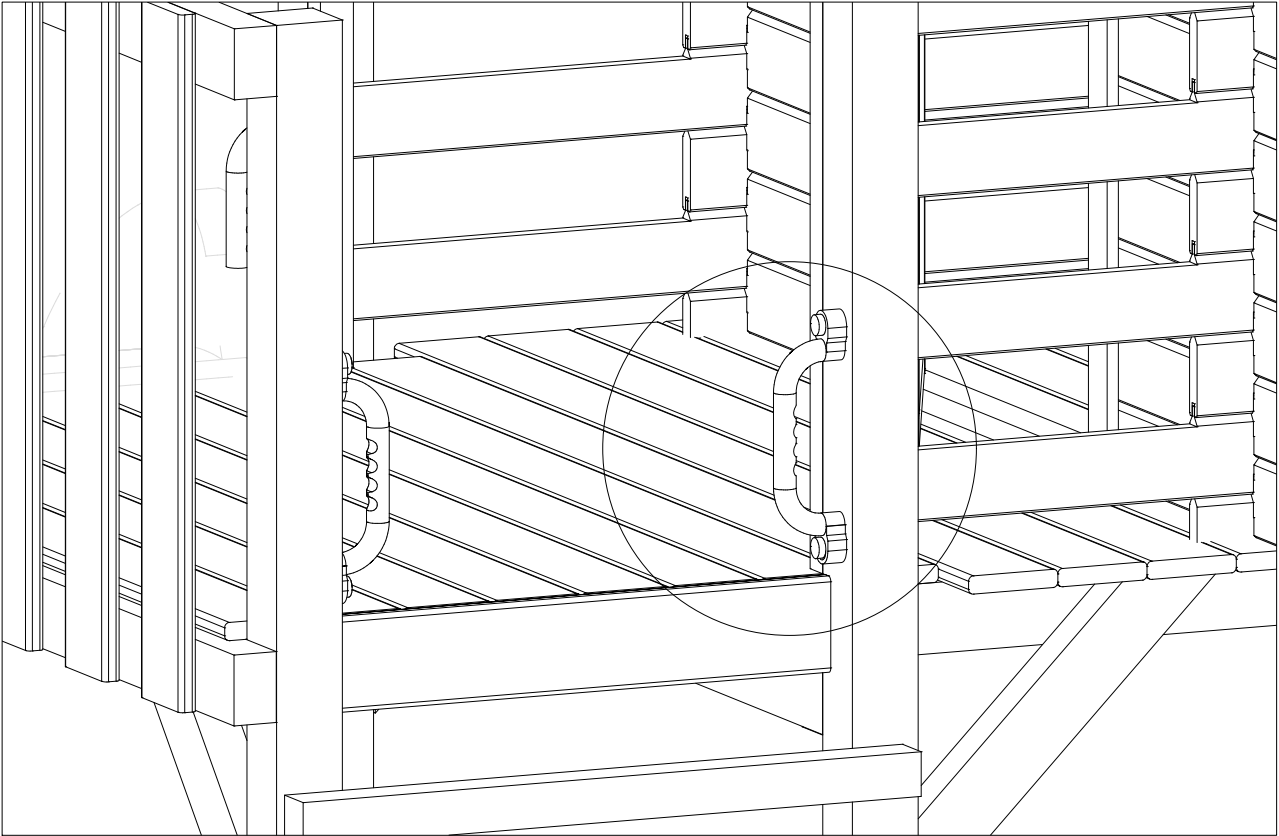

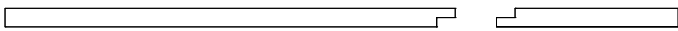
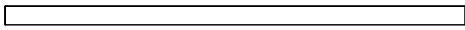
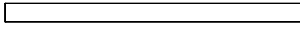
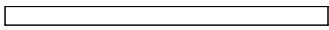
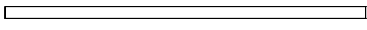
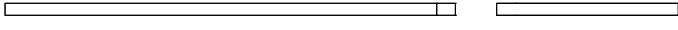
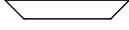
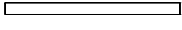
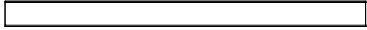

35

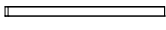

M





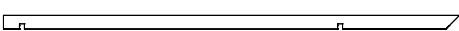
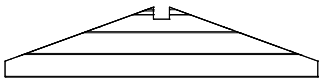
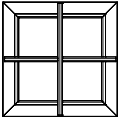
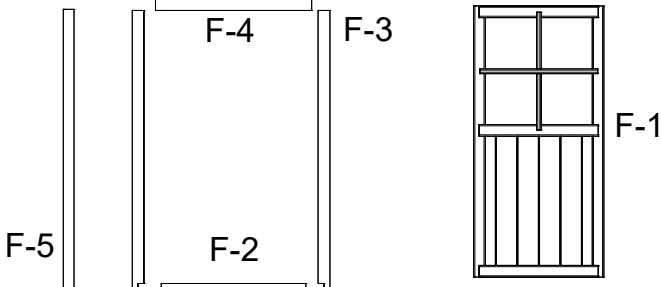

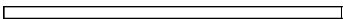
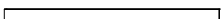

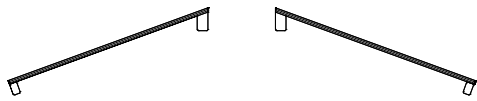





DK: Medfølger ikke !
 D:Nicht im Lieferumfang
 enthalten.
 S:Medfølger ej!

70x70		16743-1	cm (+ - 5 mm)
A-1	2		68 - 169
A-2	4		173
A-3	2		111
A-4	1		121
45x70			
A-5	3		136
A-6	4		68 - 169
A-7	8		46
44x44			
A-8	4		66
16x95			
A-9	17		136
A-10	8		121
A-11	7		69
A-12	1		54
30x30			
C	2		59
18x90			
B-9	2		134
B-2 , F	29-1		134
B-3	26		39
B-6	10		47
B-10	8		170
B-11	2		161
B-12	2		171
D	2	  E	
E	1		
F-1	1		
F-2	1		
F-3	2		
F-4	1		
F-5	1		

18x44		16743-1	cm (+ - 5 mm)
G	4		127
H-1	4		81
18x95			
H-2	4		81
45x70			
I-1&I-2	1V - 1H		176
J-1	1V	J-1	80x176
J-2	1H	J-2	
			

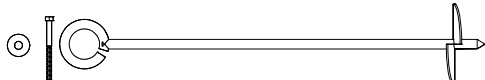
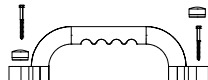
	8		6x6
B	4		9x9
			mm
	80		4,0x30
	74		4,0x40
	248		4,0x50
	54		5,0x70
	68		5,0x100
K	1		2,0x20
L	2		
M	2		4,0x70
	4		Der kan forekomme ændringer i dimensioner på brædder, elementer og skruer.
	4		



PLUS A/S, Ådalen 13B, 6600 Vejen
www.plus.dk