



Manual

9062850

DA/NO: Trampolin (original)

SV: Studsmatta (översättning)

DE: Trampolin (Übersetzung)

EN: Trampoline (translation)

518 x 305 cm



DA

SV

DE

EN

www.p-lindberg.dk
www.p-lindberg.no
www.p-lindberg.se
www.p-lindberg.de

Kontakt Danmark:

P. Lindberg A/S
Sdr. Ringvej 1
6600 Vejen
Tlf. 70 21 26 26
Fax 70 21 26 30
salg@p-lindberg.dk
www.p-lindberg.dk

Kontakt Norge:

P. Lindberg
Doneheia 62
4516 Mandal
Telefon: 21 98 47 47
hei@lindberg.no
www.p-lindberg.no

Kontakt Sverige:

P. Lindberg Sverigefilial
Myrangatan 4
745 37 Enköping
Tel. 010-209 70 50
order@p-lindberg.se
www.p-lindberg.se

Kontakt Deutschland:

P. Lindberg GmbH
Flensburger Straße 3
24969 Großenwiehe
Tel: 04604 – 9888 975
Fax: 04604 – 9888 974
kontakt@p-lindberg.de
www.p-lindberg.de

DA SIKKERHEDSANVISNINGER OG SAMLEVEJLEDNING



Trampolin, firkantet - Varenr. 9062850

Beskrivelse: Firkantet trampolin med net, måtter og stige. 518 x 305 cm.

| | |
|---|----|
| Indhold | |
| Indledning:..... | 1 |
| Indhold i kasse 1 | 3 |
| Indhold i kasse 2 | 3 |
| Indhold i kasse 3 | 4 |
| Samlevejledning RAMME: | 5 |
| Samlevejledning NET: | 10 |
| Samlevejledning STIGE: | 15 |
| Sikkerhedsanvisninger:..... | 17 |
| Instruktioner i, hvordan man hopper på trampolinen..... | 20 |
| EU overensstemmelseserklæring | 21 |

Indledning:

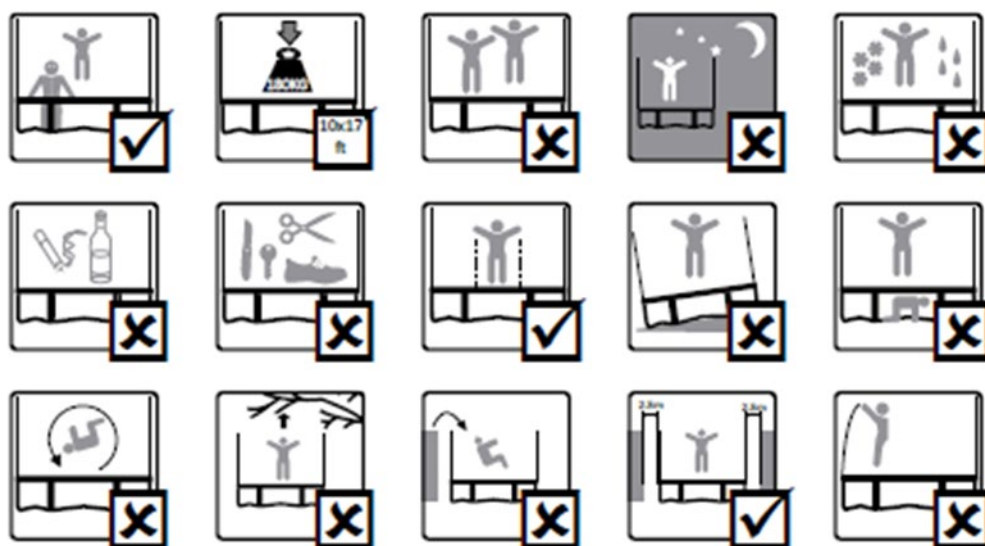

Se detaljerede sikkerhedsanvisninger bagerst i denne manual.

Læs alle sikkerhedsanvisninger og hele samlevejledningen grundigt igennem før brug og gem til evt. senere reference.

Det anbefales at være minimum 2 personer ved samling af trampolinen.

Trampolinen skal samles af en voksen i henhold til samlevejledningen og skal derefter efterses, før den tages i brug første gang.

Ønsker du at flytte trampolinen kræves der minimum to personer. Løft forsigtigt, hold trampolinen vandret og træk trampolinen til det ønskede sted.

Hvis trampolinen skal flyttes langt væk, bør den demonteres og samles forfra for ikke at beskadige den.

Hvis trampolinen ikke er i brug igennem længere tid, demonteres og pakkes den væk. Opbevares et tørt sted.



Vigtig information: Læs hele manualen grundigt igennem før samling og/eller brug af dette produkt. Følg manualen nøje og opbevar den til senere brug.



Vigtig information: Det er vigtigt at alle produkter der samles med alle former for skruer, efterspændes to uger efter samling samt hver tredje måned for at sikre, at produktet er stabilt i hele dets levetid.

Indhold i kasse 1

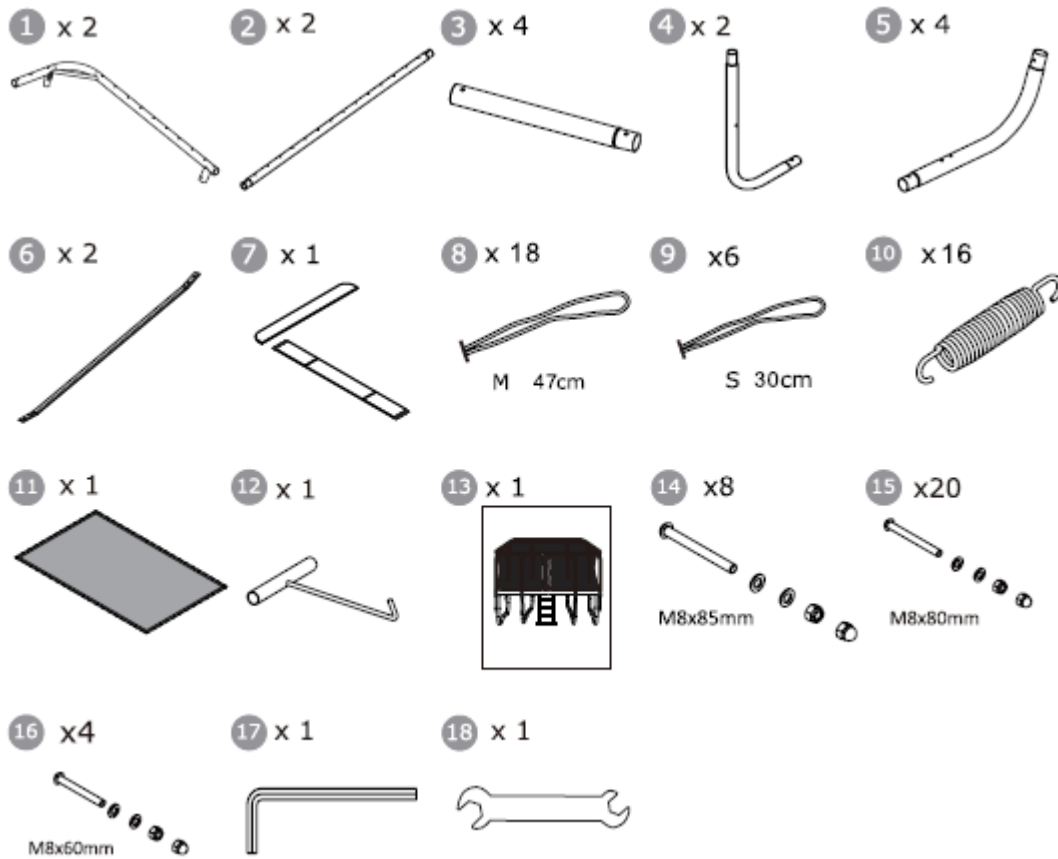

Indhold i kasse 2

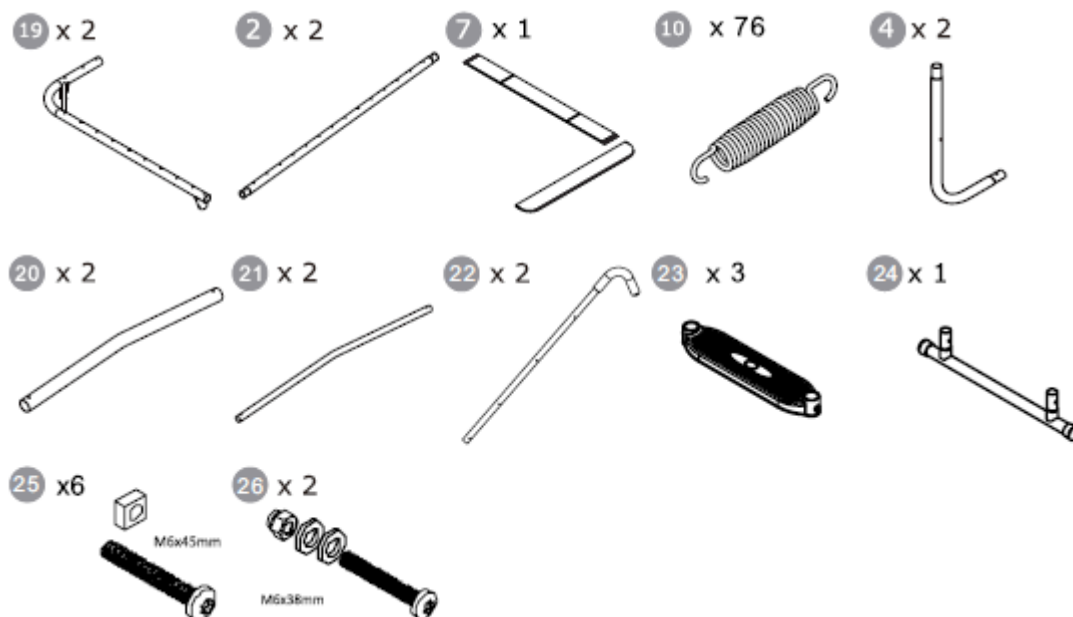

Indhold i kasse 3

27 x 8



28 x 4



29 x 4



30 x 1



31



x 2

31A



x 6

31B

32



x 2

32A



x 4

32B

33 x 8



6mm

34 x 8



18mm

35 x 8



36 x 8



37 x 8



38 x 4



39 x 8



Samlevejledning RAMME:

Komponenter:

1 x 2



2 x 4



3 x 4



4 x 4



5 x 4



6 x 2



7 x 1

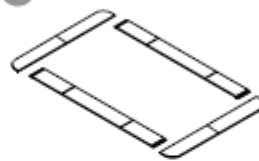

10 x 92



11 x 1

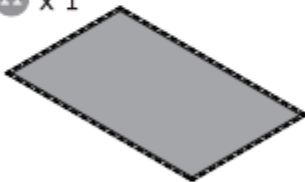

12 x 1

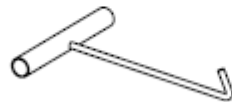

14 x 8

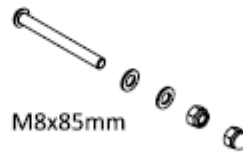

15 x 20

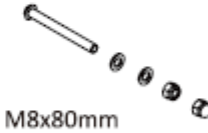

16 x 4



17 x 1



18 x 1



19 x 2



20 x 2



21 x 2



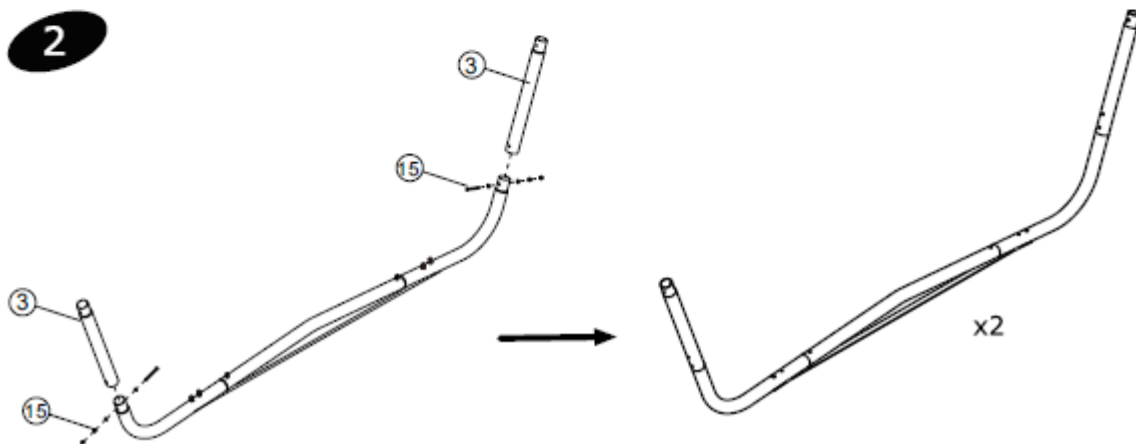
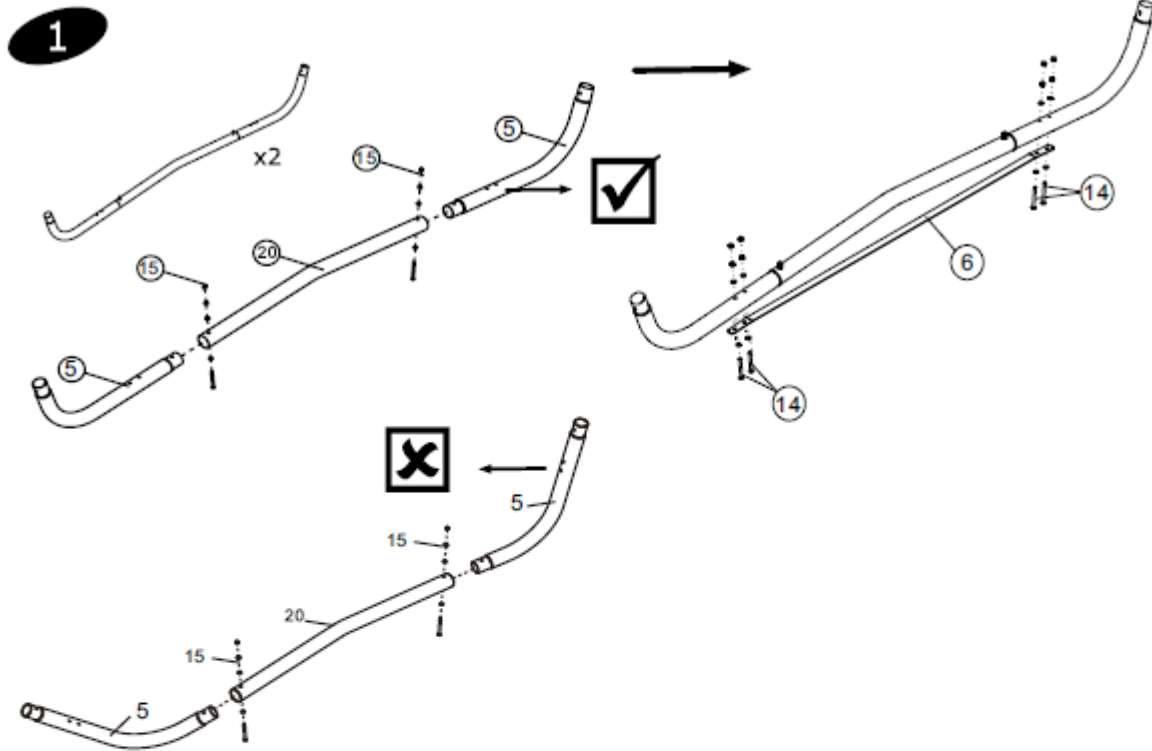

3

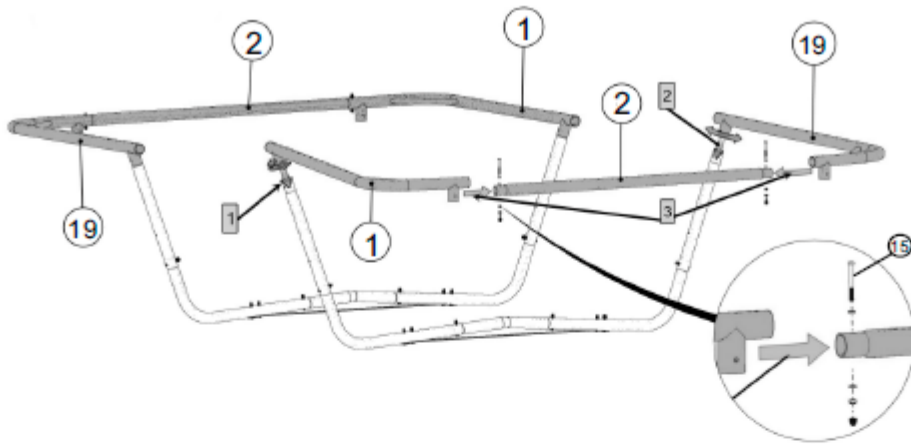

4

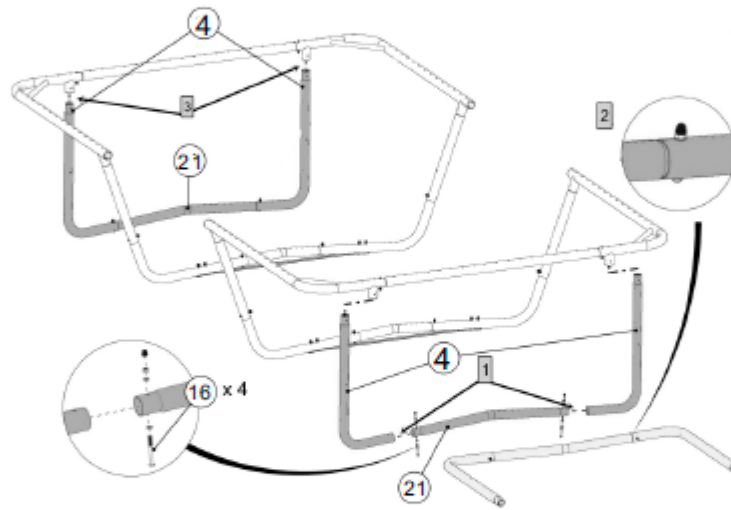

5

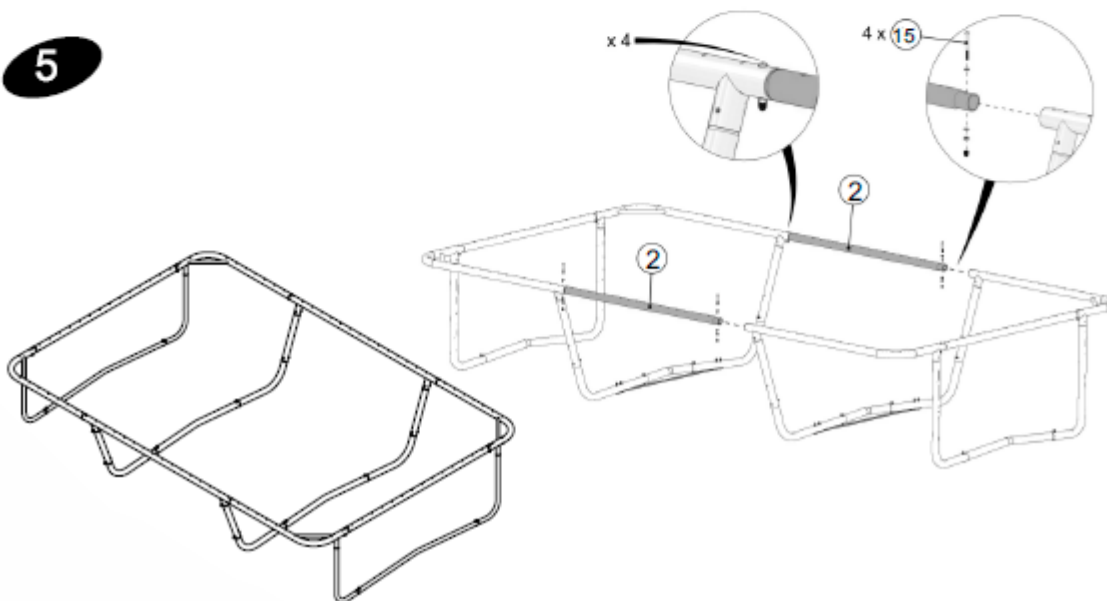

6

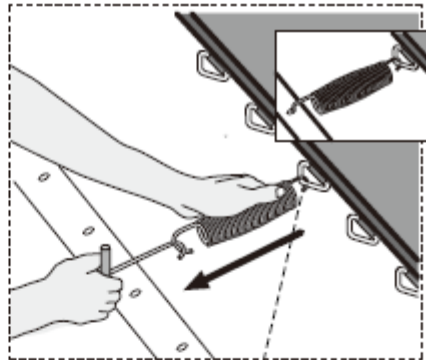
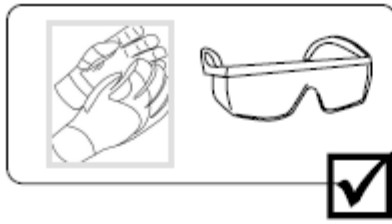

x92

1



2



3

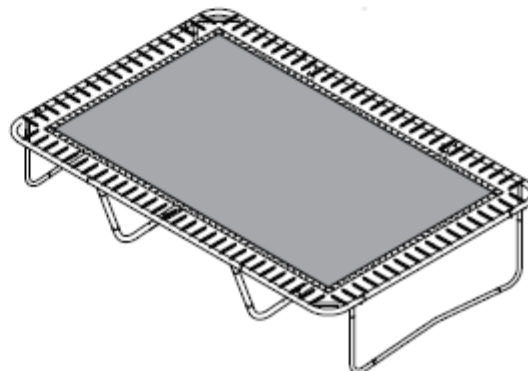

7

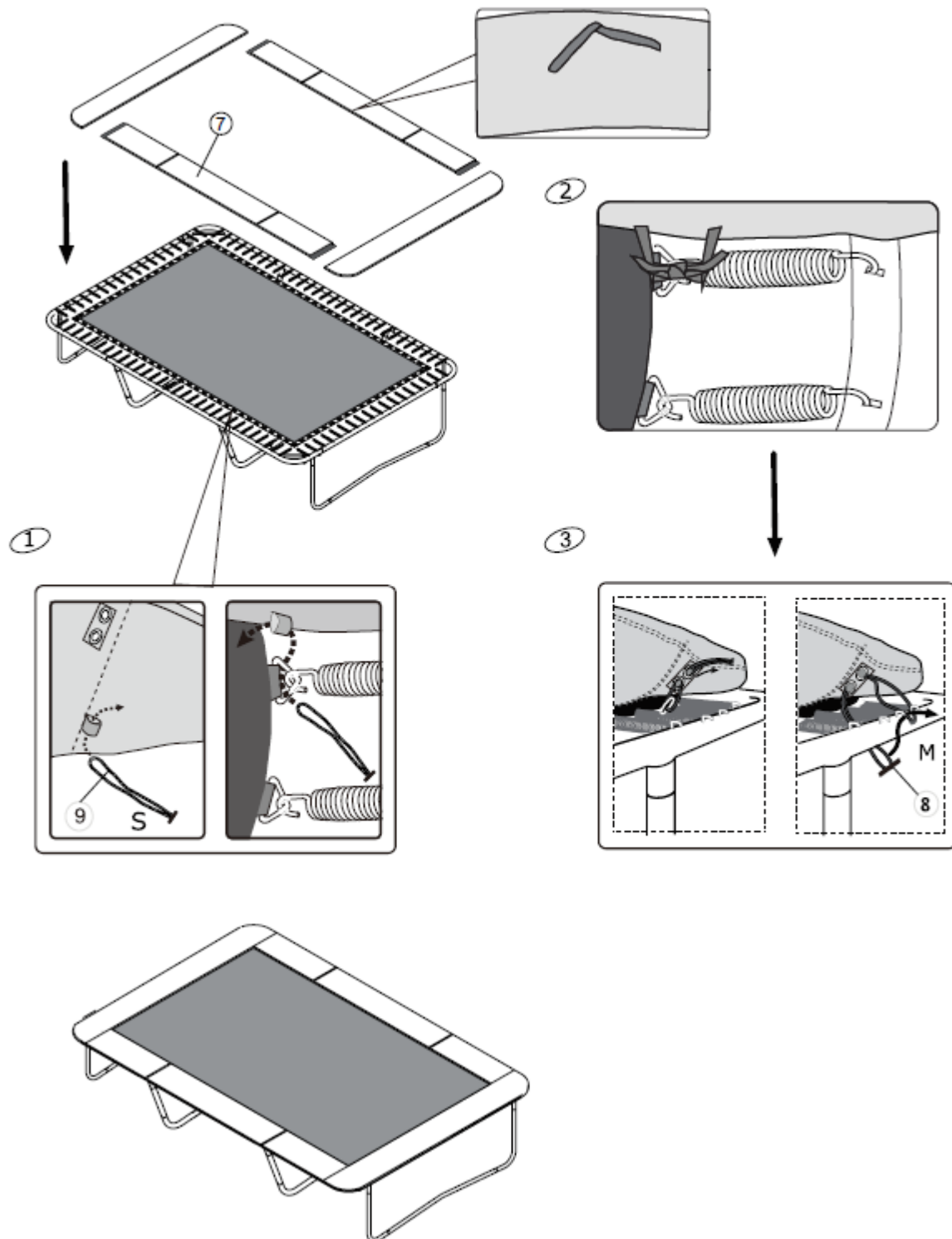

Samlevejledning NET:

27 x 8



28 x 4



29 x 4



30 x 1

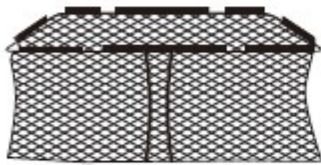

31

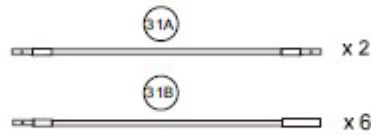

32

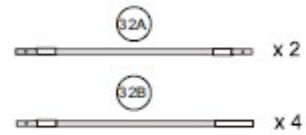

33 x 8

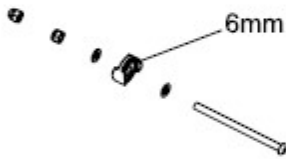

34 x 8

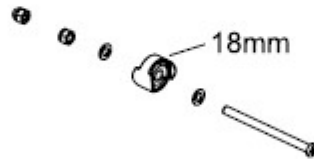

35 x 8



36 x 8



37 x 8



38 x 4

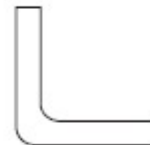

39 x 8

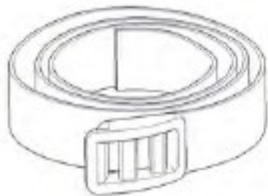

17 x 1



18 x 1





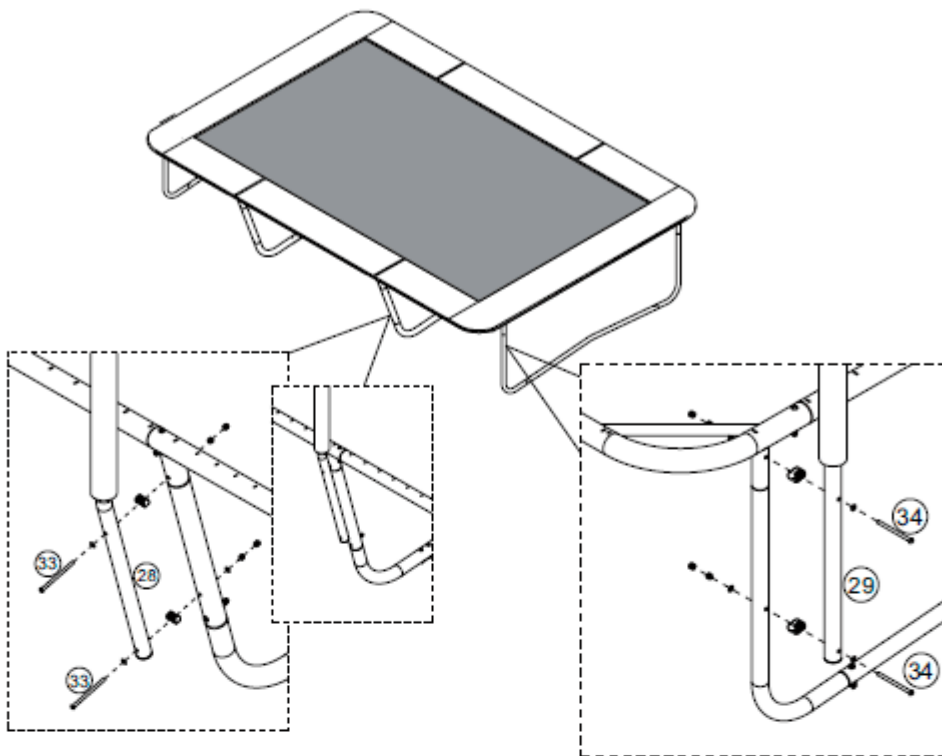

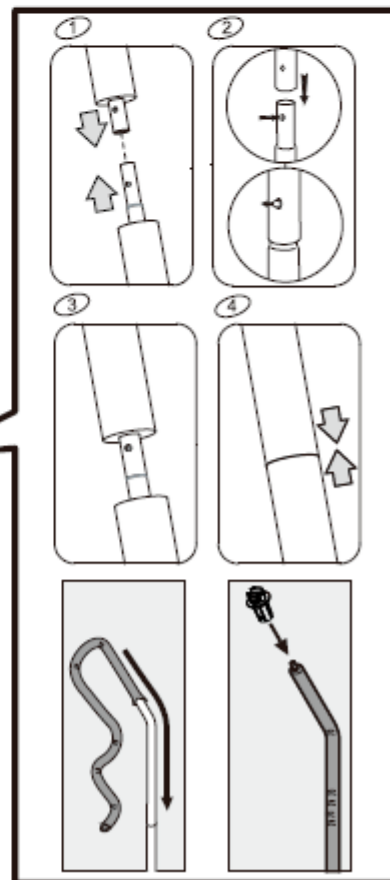
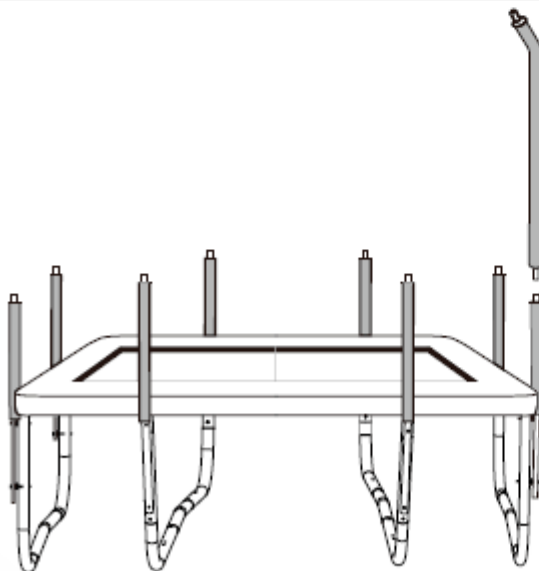

8



9



10

- 31A  x 2 31B  x 4
- 32A  x 2 32B  x 6
- 30  x 1 38  x 4 39  x 8

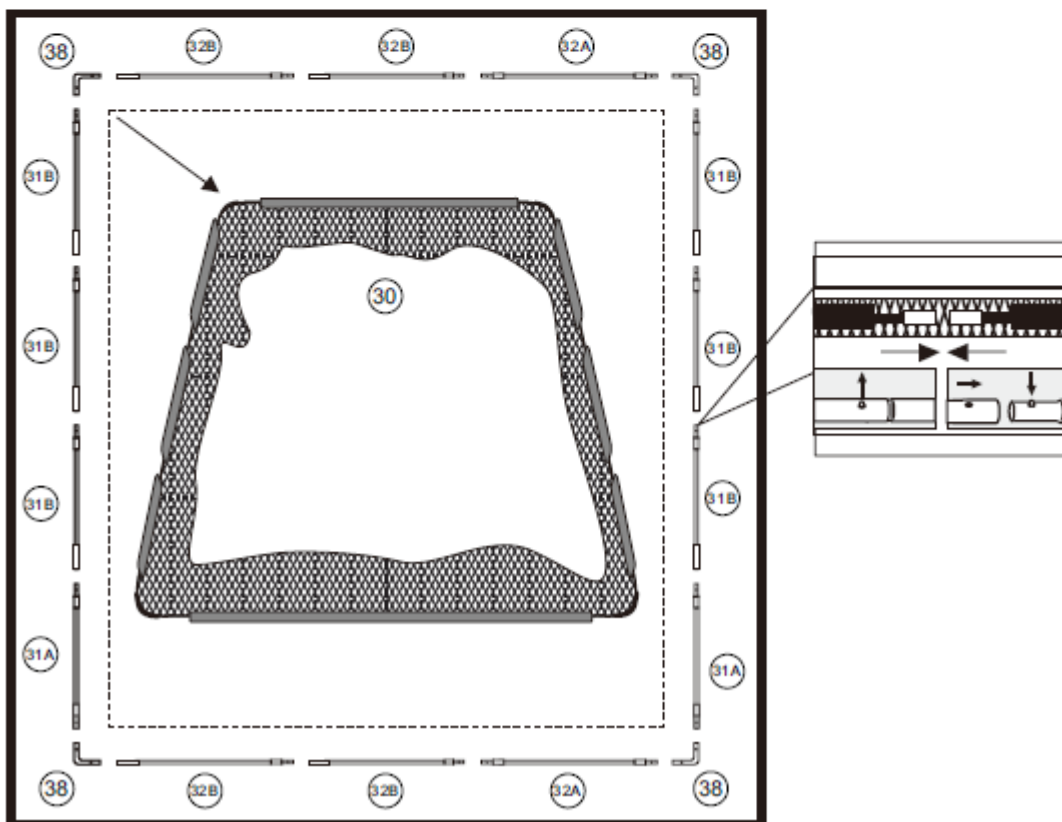
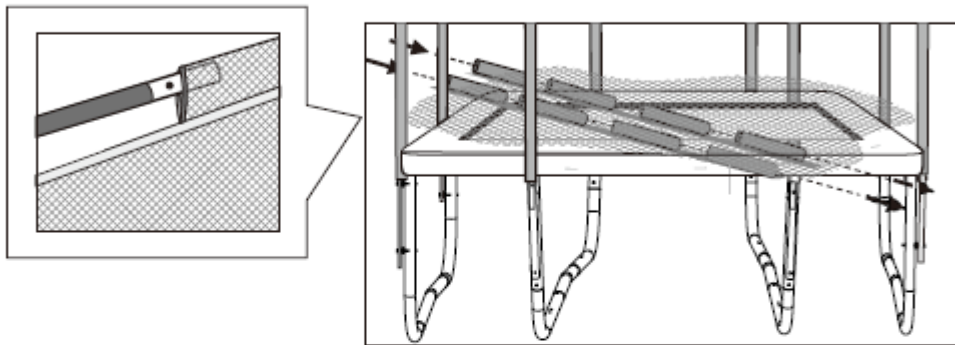

11

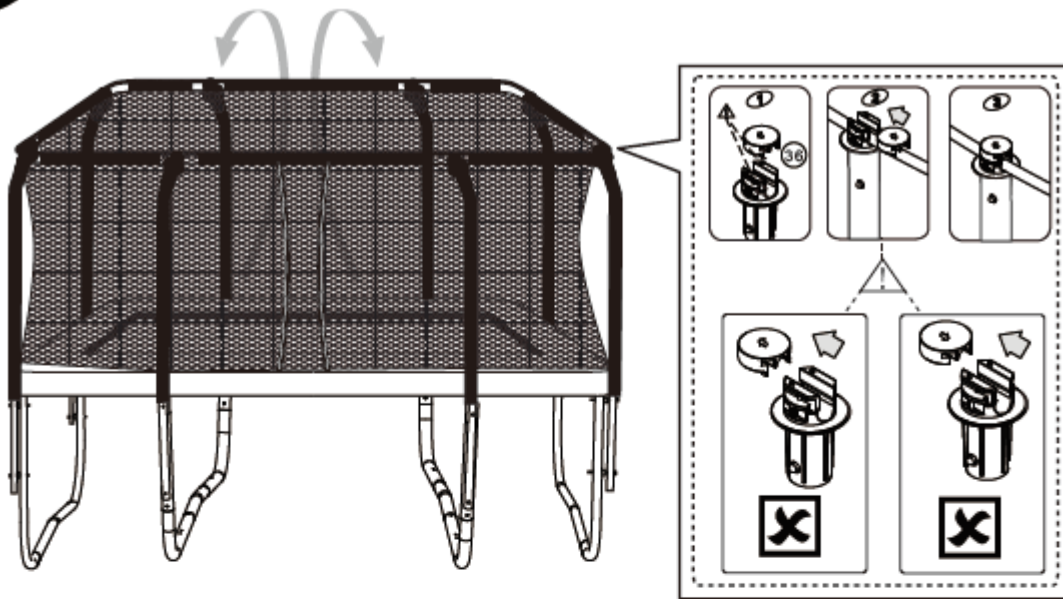

12

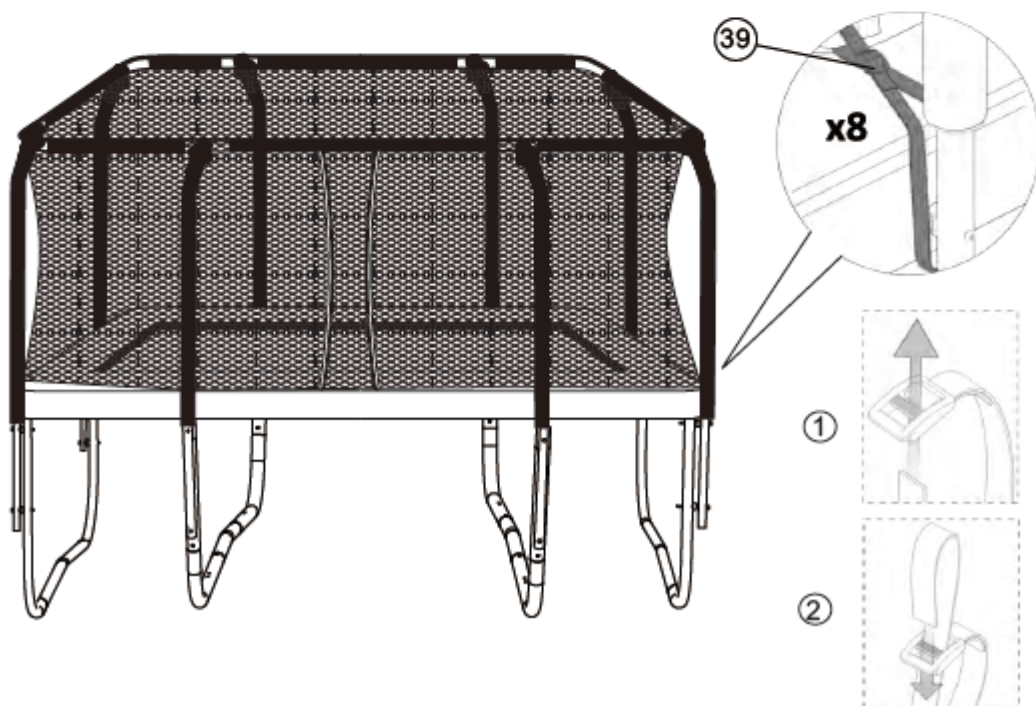

13

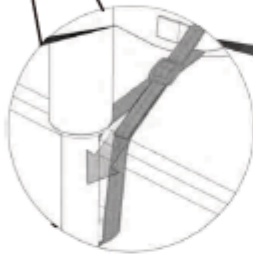
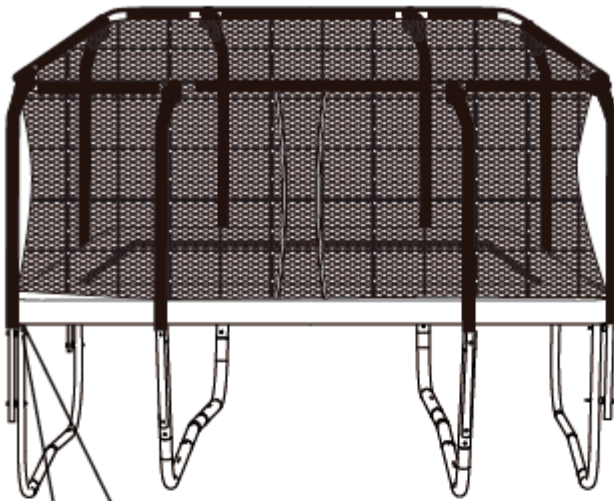

14

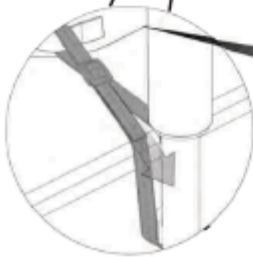
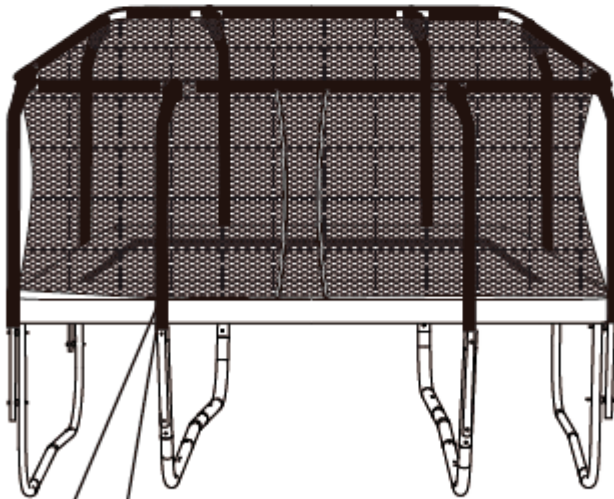

15

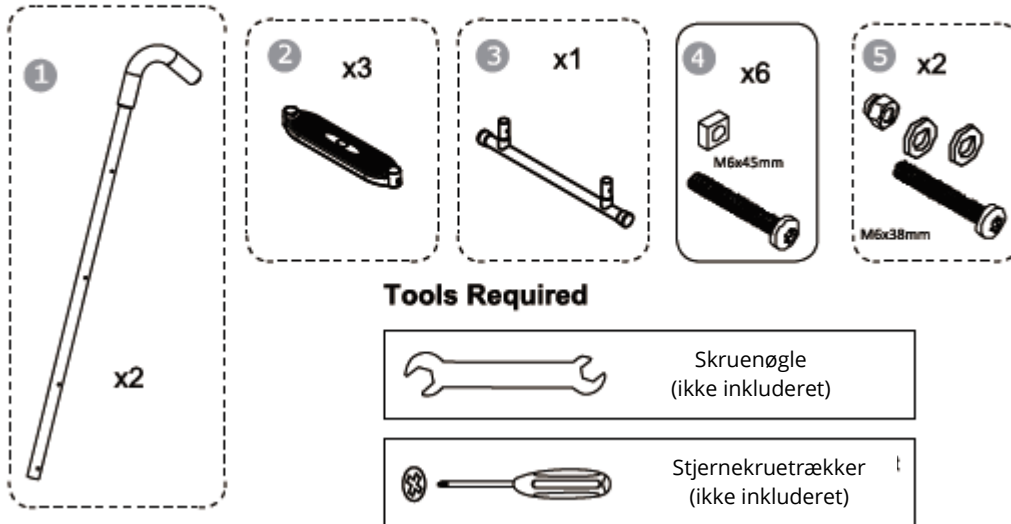

Vigtig information:

Trampolin og net bør pakkes væk om vinteren. Sørg for at alle dele er tørre og pakket forsvarligt ind. Opbevares tørt. Vær altid opmærksom på slid pga. vejr og vind.

Samlevejledning STIGE:

16

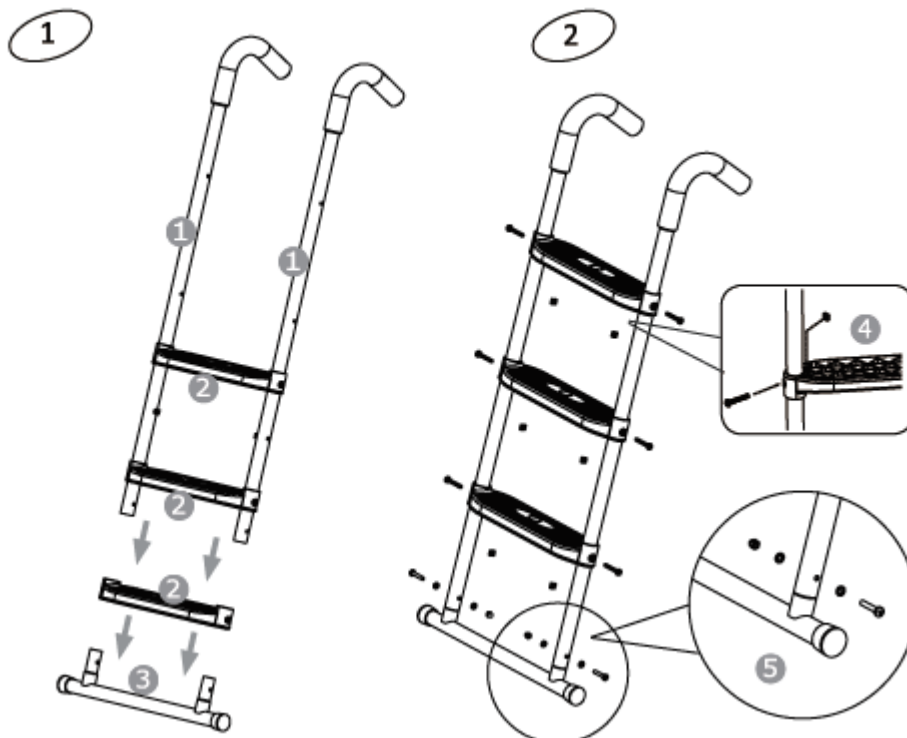

17

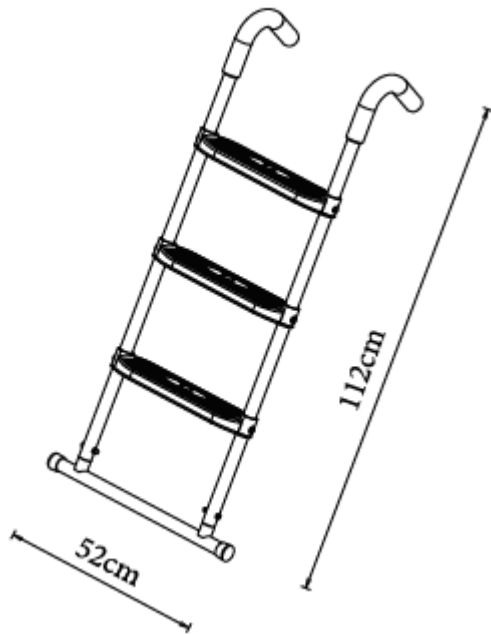

Obs indeholder små dele. Ikke egnet for børn under 3 år



Vigtig information:
Det er vigtigt at alle produkter der samles med alle former for skruer, efterspændes to uger efter samling samt hver tredje måned for at sikre, at produktet er stabilt i hele dets levetid.

18

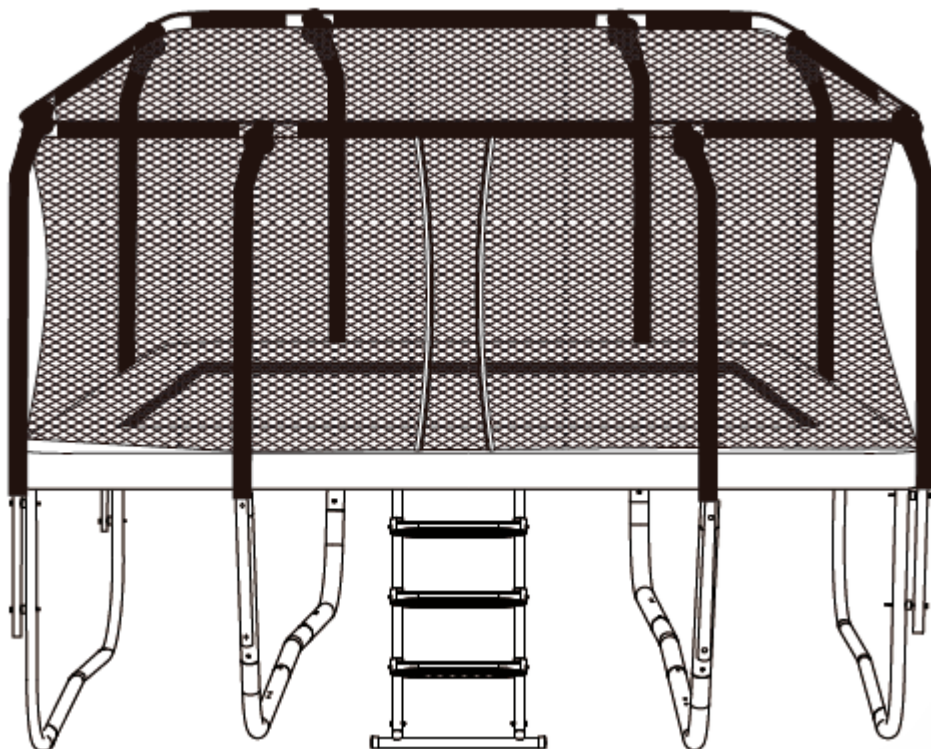

Sikkerhedsanvisninger:



Ikke egnet til børn under 3 år pga. deres manglende evne til at bruge trampolinen.

Denne trampolin er til privat brug og må kun benyttes udendørs.
Maks. belastning 160 KGS.

Ejeren eller den tilsynsførende har ansvaret for, at alle brugere er tilstrækkeligt informeret om alle sikkerhedsanvisninger og korrekt brug!



ADVARSLER

- Det er ikke tilladt for nogen at benytte trampolinen uden opsyn af en voksen, kyndig person.
- Det er kun tilladt at være 1 person på trampolinen ad gangen. Trampolinen er kun beregnet til 1 person!
- Hop aldrig 2 personer på samme tid! Det giver øget risiko for skader; herunder alvorlige skader som brud på nakke, lammelser mm.
- Lav ikke saltomortaler! Det øger risikoen for at lande på hoved eller nakke, som kan medføre alvorlige skader - i værste fald døden.
- Brug ikke trampolinen for længe ad gangen (stop regelmæssigt op).
- Sørg for at hoppe på midten af springdugen. Det kan give skader at ramme kant- puden, som absolut ikke er designet til at hoppe eller træde på.
- Vær varsom når der trædes op på trampolinen for at undgå at komme i klemme i fjedrene eller støde ind i rammen.
- Sørg altid for at kantpuden sidder korrekt og dækker ramme og fjedre for at undgå skader. Spring ikke ned fra trampolinen. Kravl forsigtigt ned for at undgå at komme til skade.
- Alle brugere bør være klar over sine egne begrænsninger. Risikoen for svære skader skal tages alvorligt. Det er vigtigt at bøje sig dybt i knæ ved landing for at opnå bedst mulig kontrol. Sæt af og land samme sted - det giver bedst kontrol. Sigt efter midter-markeringen. Få fuld kontrol over springene inden sværere spring påbegyndes.
- Det er ikke tilladt at benytte trampolinen efter indtagelse af alkohol, medicin eller andre euforiserende stoffer. Det øger risikoen for skader alvorligt, da koordineringsevne, dømmekraft og reaktionstid påvirkes.
- Rygning bør absolut undgås ved brug af trampolinen.
- Benyt ikke trampolinen, hvis du lider af forhøjet blodtryk.
- Benyt ikke trampolinen, hvis du er gravid.
- Spring aldrig ned på trampolinen fra tag eller forhøjninger. Det øger risikoen for skader.
- Træk ikke dig selv op på trampolinen ved hjælp af kantpuden.

- Benyt ikke trampolinen, hvis den er våd. Springdugen bliver glat, og det øger risikoen for, at springeren falder og får skader
- Benyt ikke trampolinen i stærk blæst. Det kan bringe springeren ud af kontrol og dermed medføre alvorlige skader.
- Trampolinen skal inspiceres for fejl før brug HVER gang. Efterspænd beslag og tjek med jævne mellemrum om alle bånd er bundet korrekt.
- Udskift slidte eller defekte dele. Mangler skal udbedres. Sørg for at holde trampolinen fri for alger, jord mm.
- Brug ikke sko, støvler eller andet fodtøj på trampolinen.
- Sørg for at tøj og lommer ikke indeholder skarpe genstande ved brug af trampolinen.
- Lad ikke kæledyr opholde sig på trampolinen. Skarpe kløer kan beskadige springdugen.
- Hvis der bruges stige til op- og nedstigning af trampolinen, vær da særligt opmærksom på, at trampolinen ikke bliver brugt uden opsyn! Fjern evt. stigen.
- Benyt ikke trampolinen efter mørkets frembrud.
- Sørg for at holde lynlåsen på nettet lukket, når trampolinen er i brug. Husk at nettet ikke er konstrueret til at springe ind i for mere fart og hurtigere afsæt!
- Sørg for, at velcrobåndene er lukket korrekt, når trampolinen er i brug.
- Tjek med jævne mellemrum at nettet er monteret korrekt. Efterspænd monterings- beslag.
- Trampolinen og nettet skal inspiceres for fejl før brug HVER gang. Efterspænd beslag og tjek med jævne mellemrum om alle bånd er bundet korrekt. Udskift slidte eller defekte dele. Mangler skal udbedres.
- Inden sæsonstart skal der udføres vedligeholdelse på trampolinen.
- Regelmæssig vedligeholdelse er påkrævet. Manglende udførelse af regelmæssig vedligeholdelse kan medføre risiko for brugerne.
- Kontrollér at alle møtrikker og skruer er strammet til og stram dem til, når der er behov for det.
- Kontrollér, at alle fjederbelastede (stift) samlinger stadig er intakte og ikke kan gå løs under leg.
- Må kun anvendes af én person ad gangen, da der er risiko for sammenstød.
- Det er forbudt at lave saltomortaler.
- Må kun anvendes under voksenopsyn.
- Tjek alle beskyttelses kapper til bolte for skarpe kanter og udskift hvis nødvendigt.
- Ændringer, som forbrugeren selv foretager på den oprindelige trampolin (eksempelvis tilføjelse af tilbehør), skal udføres i henhold til producentens vejledning.



ADVARSLER

Placering af trampolin:

- Der skal være minimum 7,3 meters frihøjde. der må ikke være nogen form for genstande i dette område.
- Trampolinen skal placeres på en jævn overflade.
- Underlaget må ikke være beton, fliser eller asfalt.
- Der må ikke være genstande under trampolinen.

- Trampolinen skal placeres i passende afstand (minimum 2,5 m) fra el ledninger, svømmebassiner, hegn, træer og grene, legestativer eller andre genstande.

Vedligeholdelse:

Rengøring af springdugen foretages med en fugtig klud for at fjerne evt. alger, snavs mm. Tør efter med en tør klud. Brug ikke trampolinen før denne er helt tør igen. Brug af rengøringsmidler eller andre kemikalier er ikke tilladt til rengøring af produktet. Efterspænd med jævne mellemrum alle beslag og tjek at beskyttelsesmåtten er korrekt monteret.

Yderligere information:

Det anbefales at stormsikre trampolinen ved stærk blæst. Sur trampolinen fast med reb, som fastgøres til rammen. Brug minimum 3 surringer jævnt fordelt over trampolinens ramme. Fastgør ikke kun benene, da disse kan trækkes skæve og ødelægge trampolinen. Demonter eller fjern evt. trampolinen helt. Det kan medføre stor fare, hvis trampolinen ikke fastgøres i stærk blæst.





ADVARSEL:

- Sikkerhedsnet skal udskiftes efter 2 år.
- Sikkerhedsnettet skal lukkes, før der hoppes på trampolinen.
- Det er ikke tilladt at spise, mens der hoppes på trampolinen.
- Trampolinen er ikke beregnet til at blive gravet ned i jorden.
- I visse lande kan vægten fra sneen og de meget lave temperaturer om vinteren beskadige trampolinen. Det anbefales at fjerne sneen og opbevare måtten og sikkerhedsnettet indendørs.

Instruktioner i, hvordan man hopper på trampolinen



EU overensstemmelseserklæring

| | |
|--|--|
| EU OVERENSSTEMMELSESERKLÆRING  | |
| EU – importør: | P. Lindberg A/S Sdr. Ringvej 1 6600 Vejen Tlf.: 70212626 E-mail: salg@p-lindberg.dk CVR: 25903110 www.p-lindberg.dk |
| Erklærer herved at følgende maskine: | Firkantet trampolin 512 x 305 cm. PL varenr.: 9062850 |
| Type / model: | TATR-1017BR |
| Er i overensstemmelse med følgende direktiver: | 2009/48/EC |
| Anvendte standarder og normer: | EN 71-1:2014 + A1:2018 EN 71-2:2011+A1:2014 EN 71-14:2018 EN 71-3:2019 |
| Dato og ansvarlig underskrift: | Vejen d. 16-11-2020 P. Lindberg A/S  Erik T Lauritsen Direktør  |

Vi forbeholder os ret til uden foregående varsel at ændre de tekniske parametre og specifikationer for dette produkt.

SV SÄKERHETSANVISNINGAR OCH MONTERINGSANVISNINGAR



Studsmatta, fyrkantig - Art. 9062850

Beskrivning: Fyrkantig studsmatta med nät, matta och steg. 518 x 305 cm.

Innehåll

| | |
|--|----|
| Inledning..... | 1 |
| Innehåll i box 1 | 3 |
| Innehåll i box 2 | 3 |
| Innehåll i box 3 | 4 |
| Montering RAM..... | 5 |
| Montering NÄT..... | 10 |
| Montering STEGE..... | 15 |
| Säkerhetsanvisningar..... | 17 |
| Instruktioner om hur man ska hoppa på studsmattan..... | 20 |
| EU-Försäkran om överensstämmelse..... | 21 |

Inledning

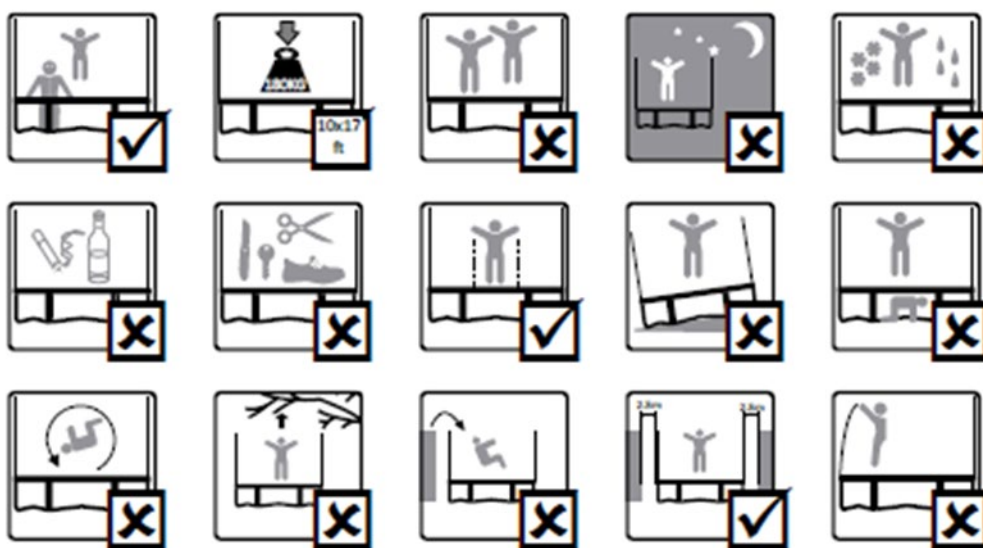

Se detaljerade säkerhetsanvisningar längst bak i manualen.

Läs alla säkerhetsanvisningar och hela monteringsanvisningen grundligt innan produkten tas i bruk. Det rekommenderas att vara minst 2 personer vid montering av studs mattan. Studsmattan ska monteras av en vuxen enligt monteringsanvisningen, studsmattan ska efterses och kontrolleras minst en gång i månaden.

Om du önskar att flytta studsmattan krävs det två vuxna personer. Lyft försiktigt och bär studsmattan till önskad position. Om studsmattan ska flyttas lång bit rekommenderas det att montera ned den.

Om studsmattan inte används under en längre period bör den monteras ner och ställas undan på en torr plats.



Viktig information: Läs hela manualen grundligt inför montering och användning av produkten. Följ manualen noga.



Viktig information: Det är viktigt att alla delar som monteras efterspänns efter en veckas bruk, därefter var tredje månad för att vara säker på att studsmattan förblir stabil.

Innehåll i box 1

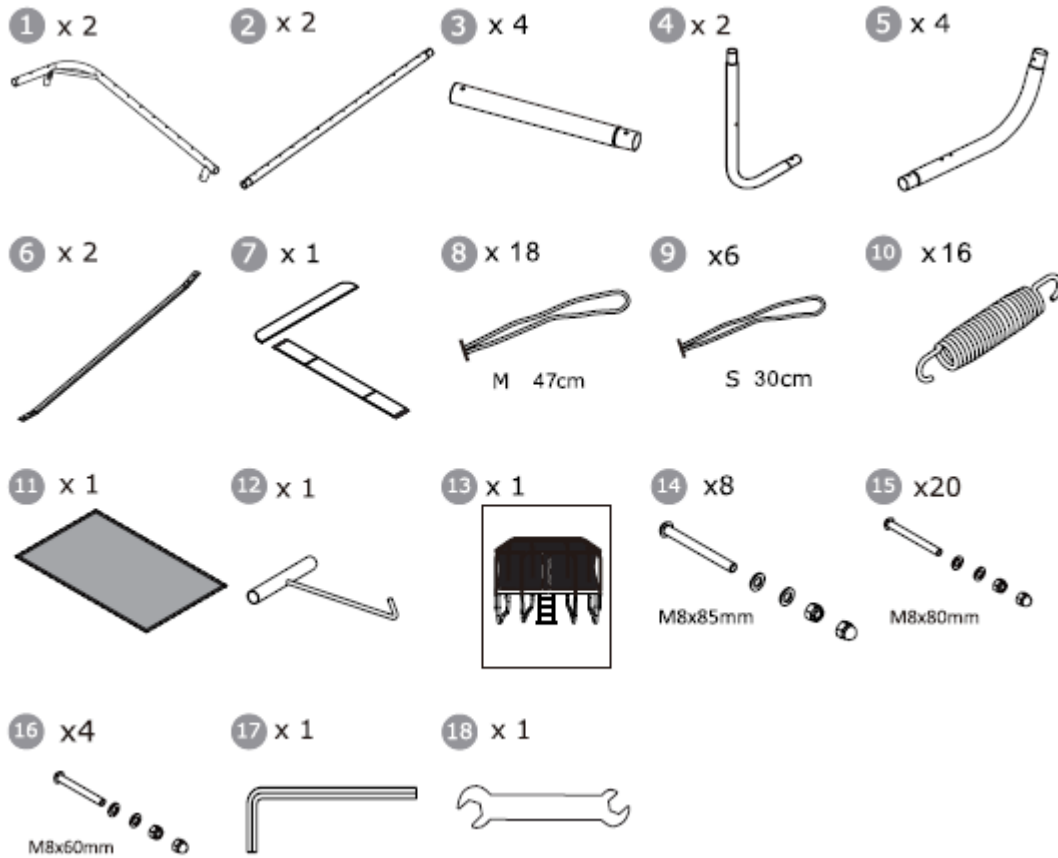

Innehåll i box 2

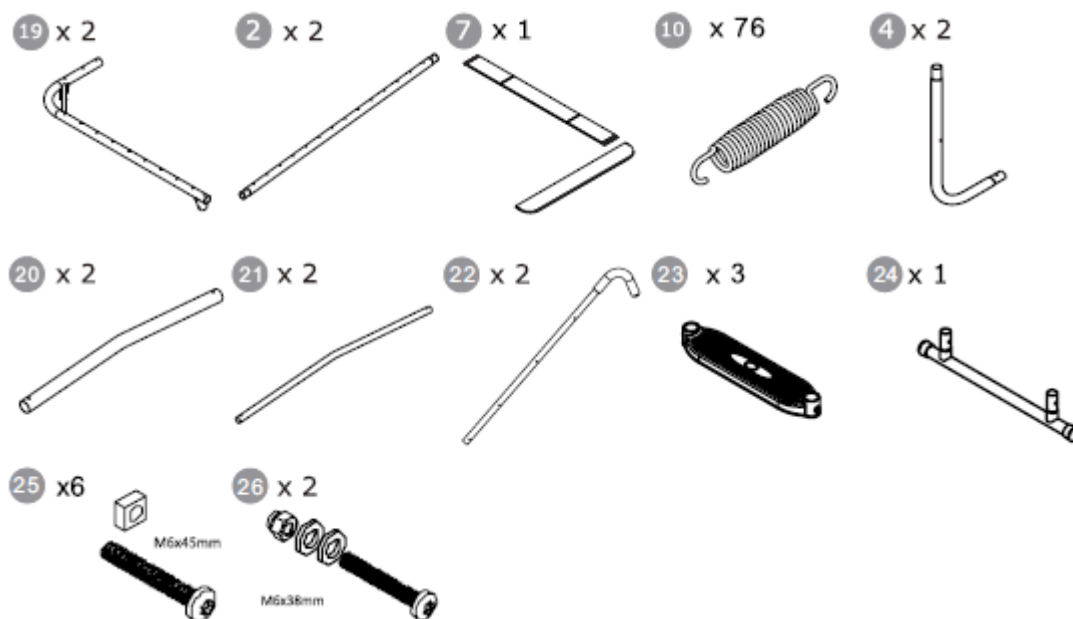

Innehåll i box 3

27 x 8



28 x 4



29 x 4



30 x 1



31



31A



31B

32



32A



32B

33 x 8



34 x 8



35 x 8



36 x 8



37 x 8



38 x 4



39 x 8



Montering RAM Komponenter

1 x 2



2 x 4



3 x 4



4 x 4



5 x 4



6 x 2



7 x 1

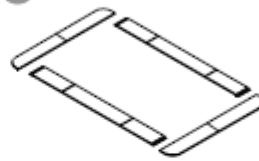

10 x 92



11 x 1

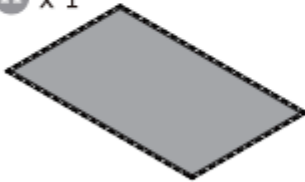

12 x 1

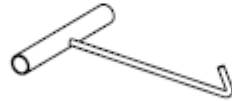

14 x 8

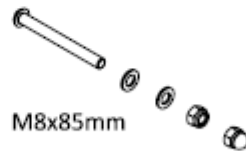

M8x85mm

15 x 20

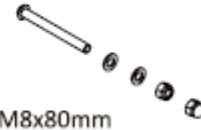

M8x80mm

16 x 4

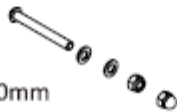

M8x60mm

17 x 1



18 x 1



19 x 2



20 x 2



21 x 2



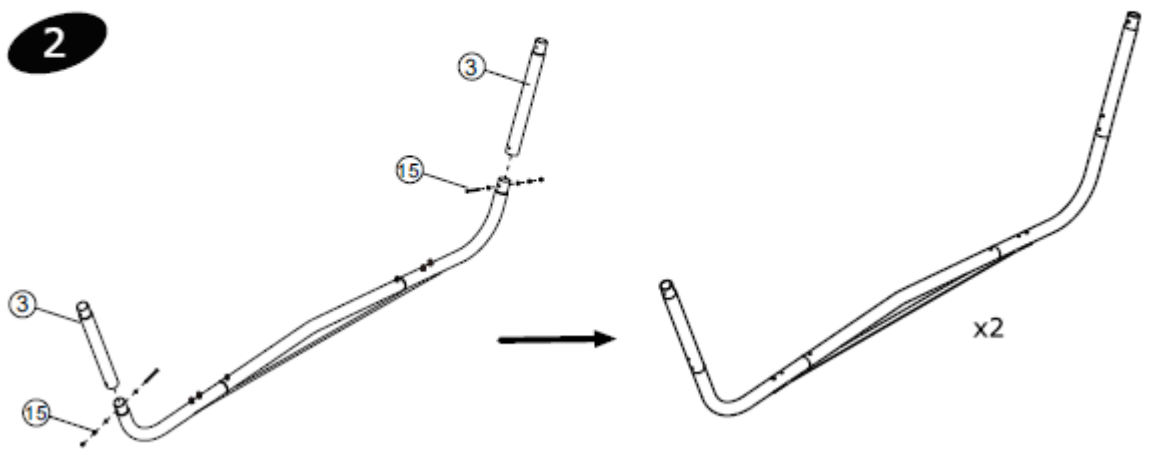
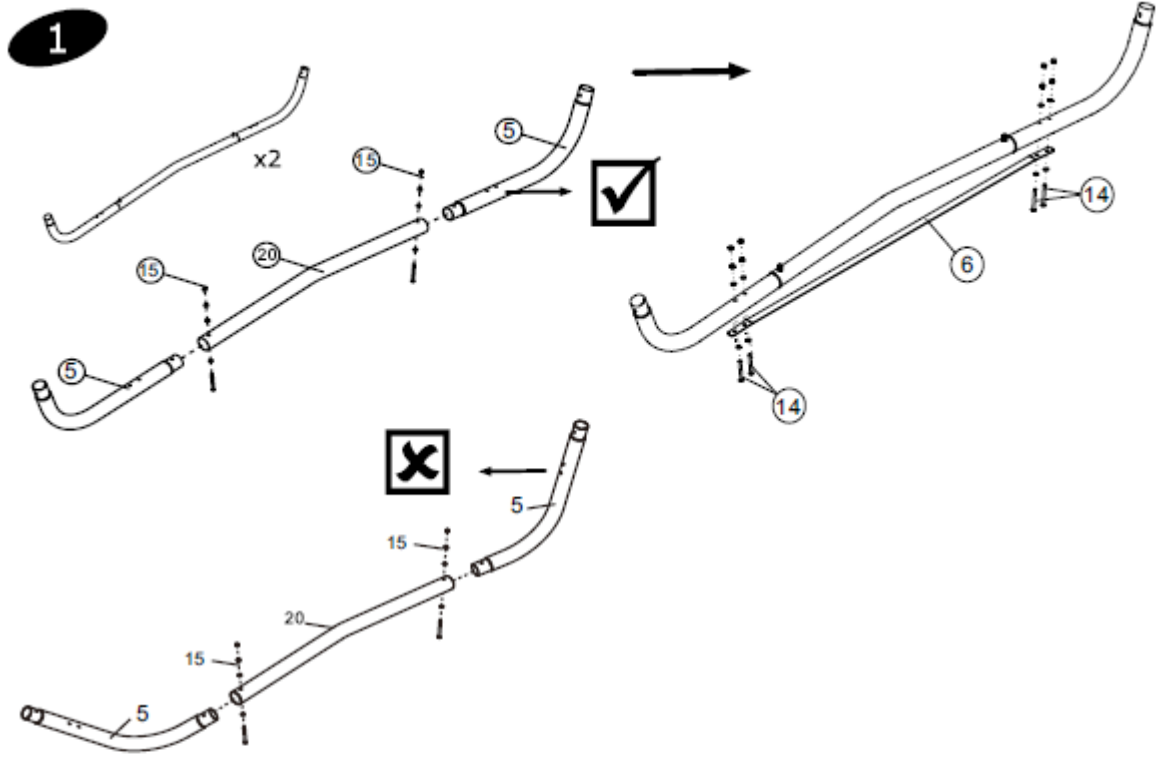

3

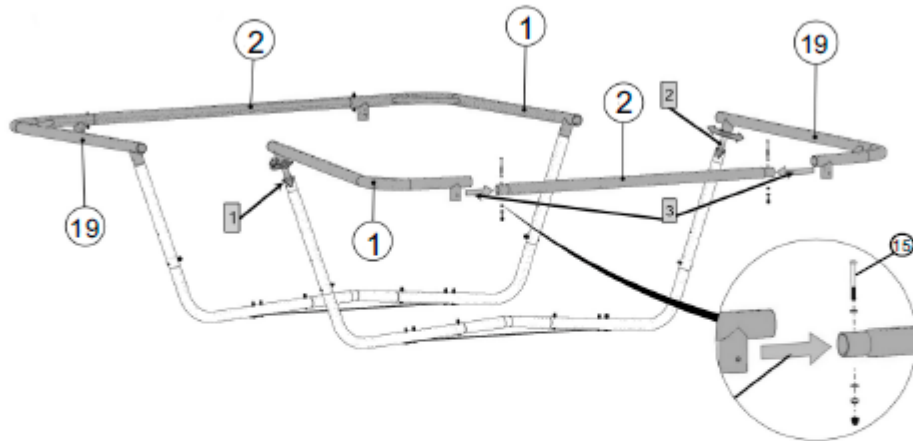

4

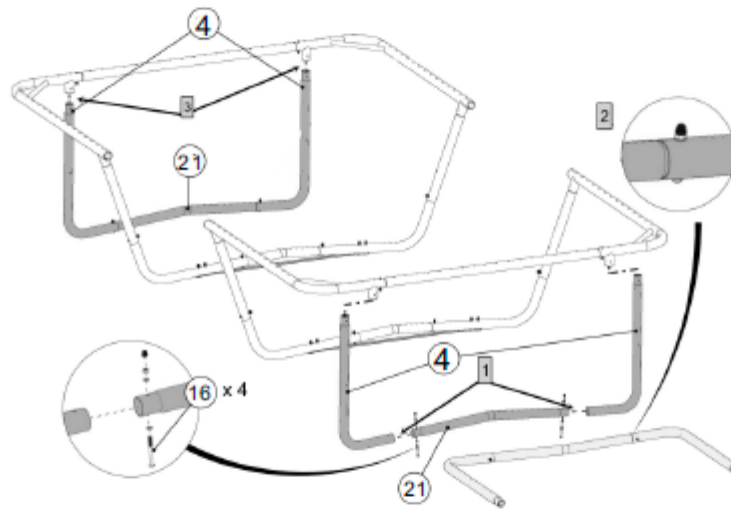

5

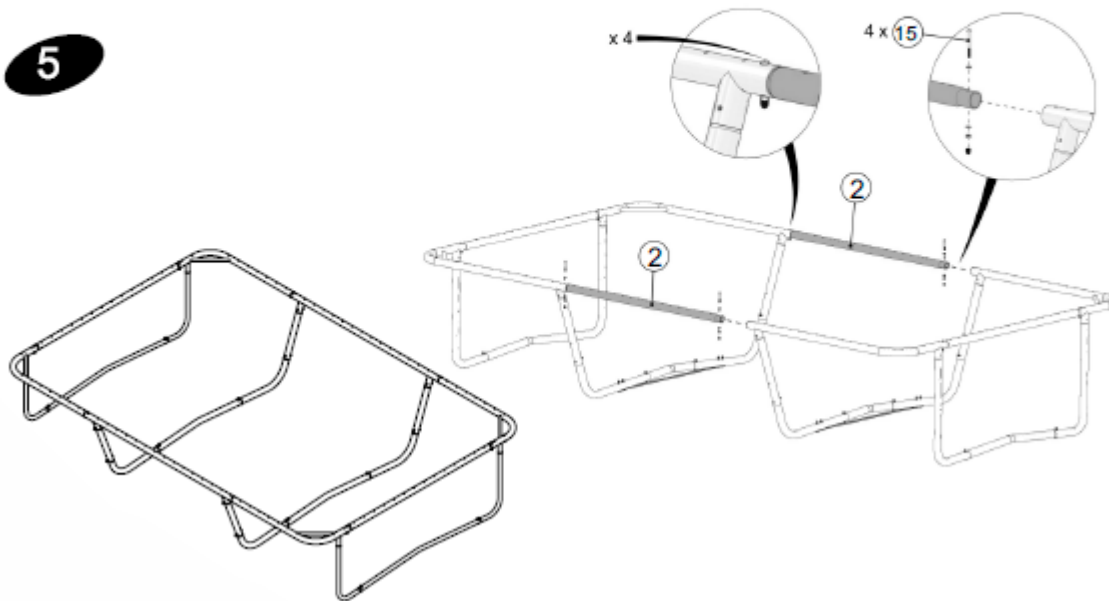

6

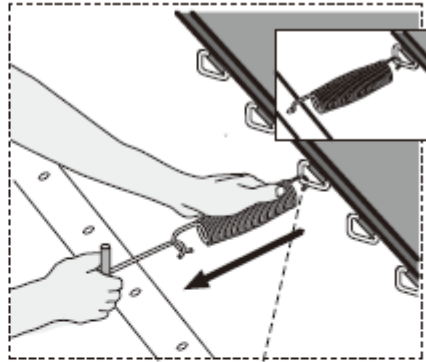
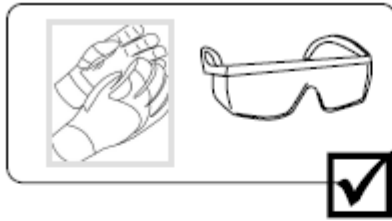

x92

1



2



3

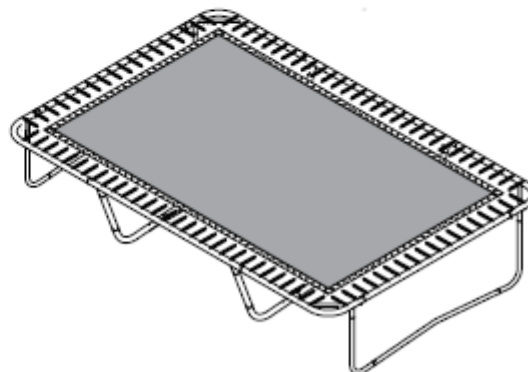

7

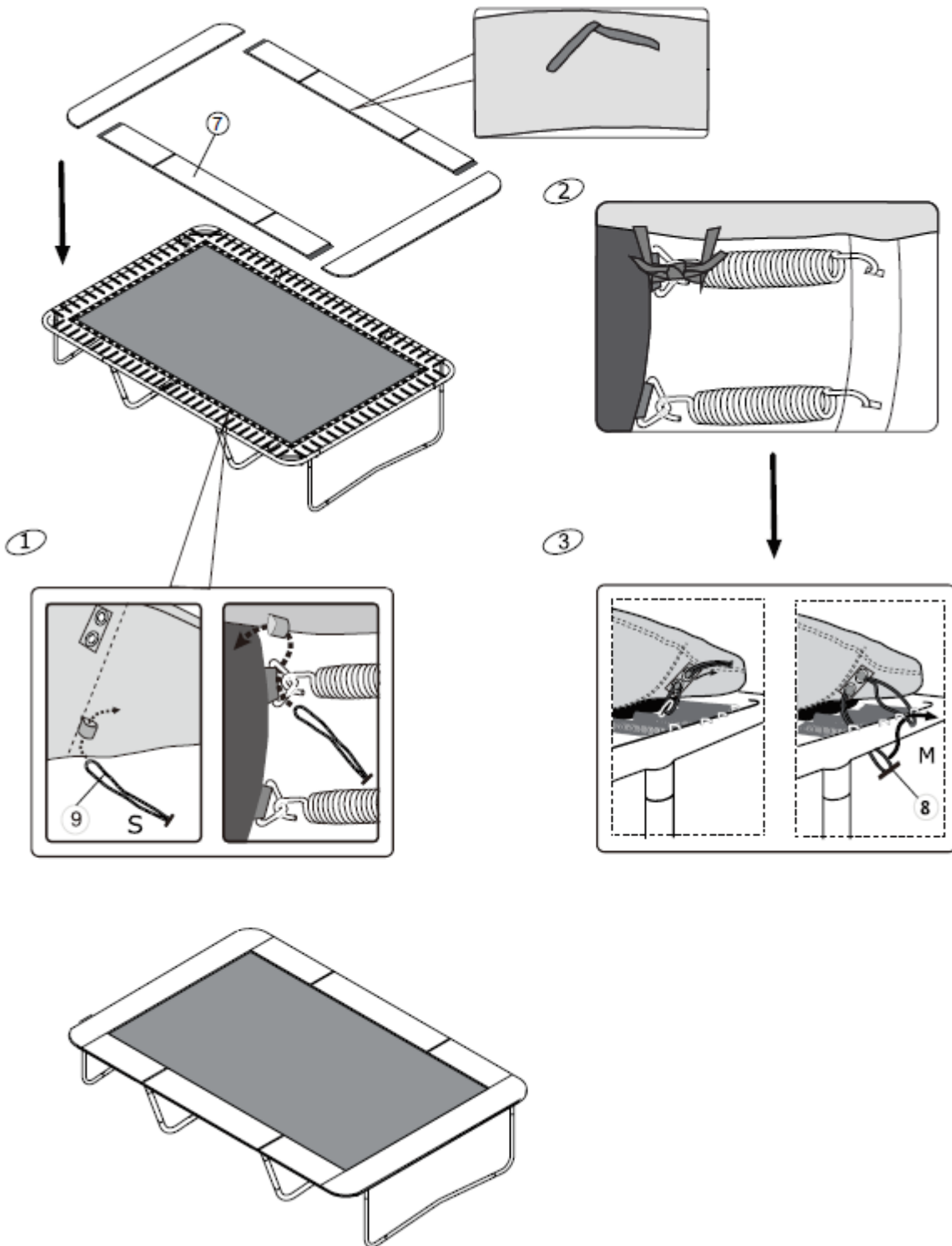

Montering NÄT

27 x 8



28 x 4



29 x 4



30 x 1

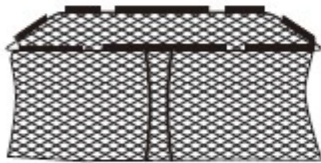

31



32

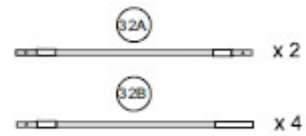

33 x 8

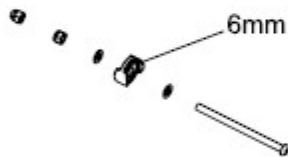

34 x 8

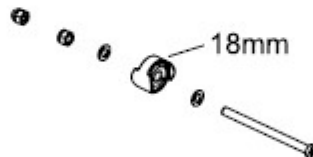

35 x 8



36 x 8



37 x 8



38 x 4



39 x 8



17 x 1



18 x 1





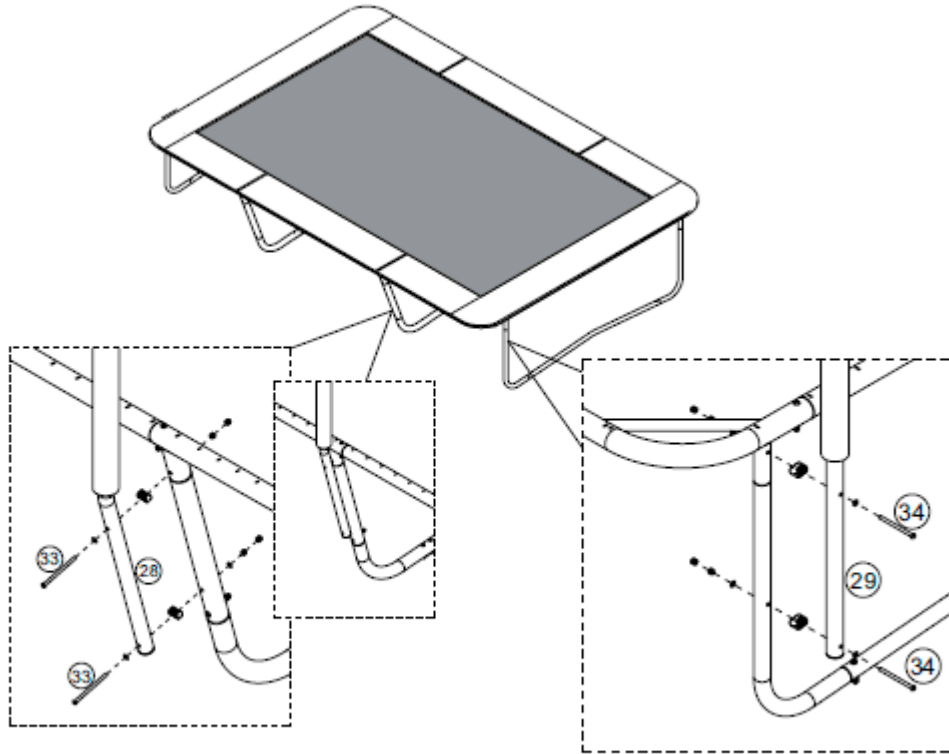

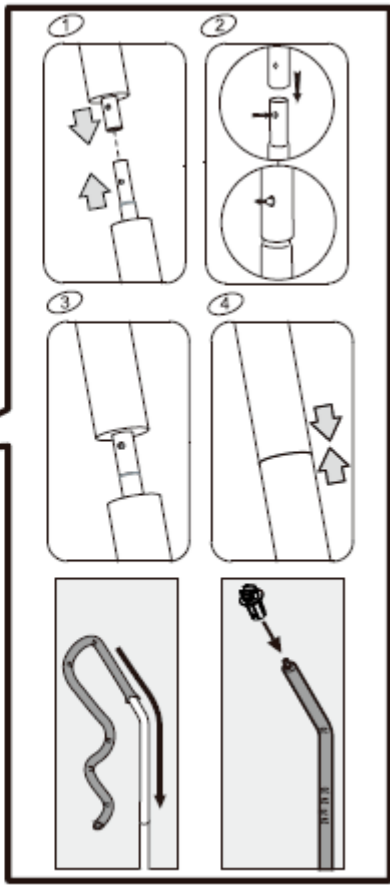
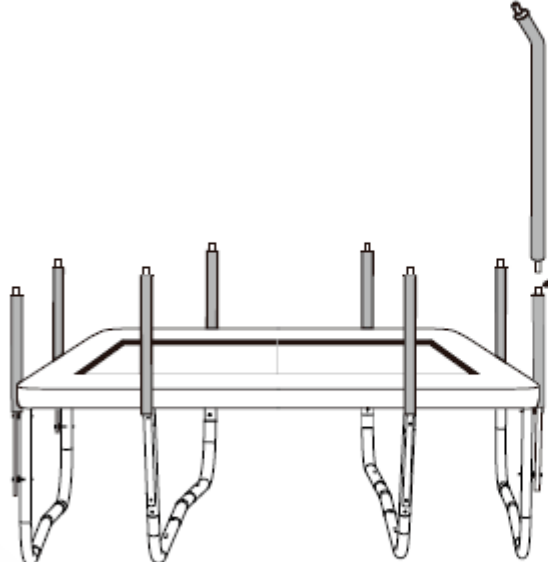
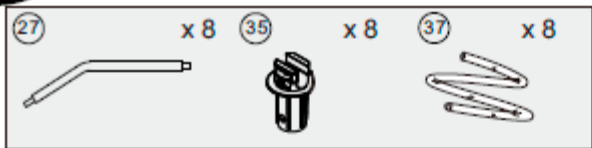

8



9



10

- 31A  x 2 31B  x 4
- 32A  x 2 32B  x 6
- 30  x 1 38  x 4 39  x 8

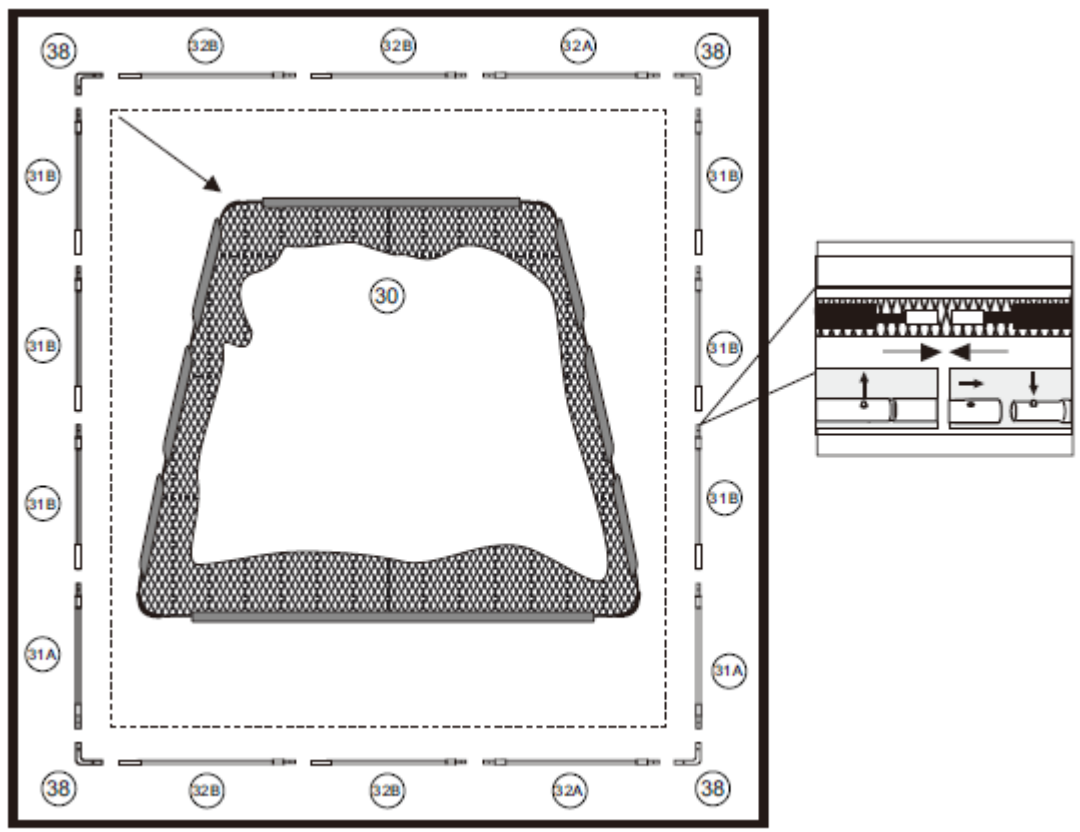
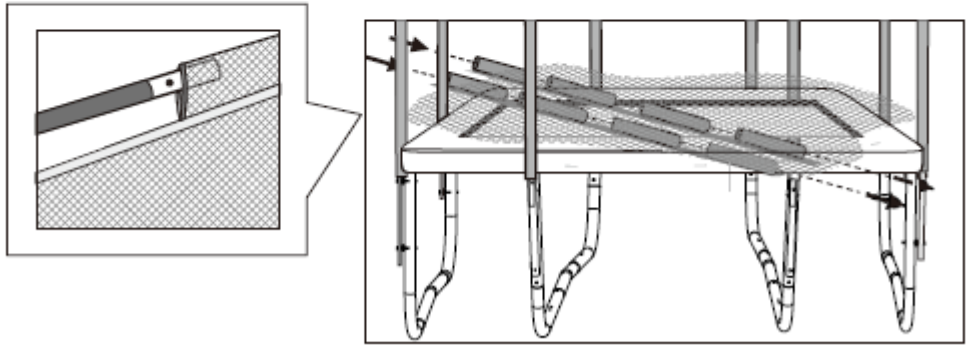

11

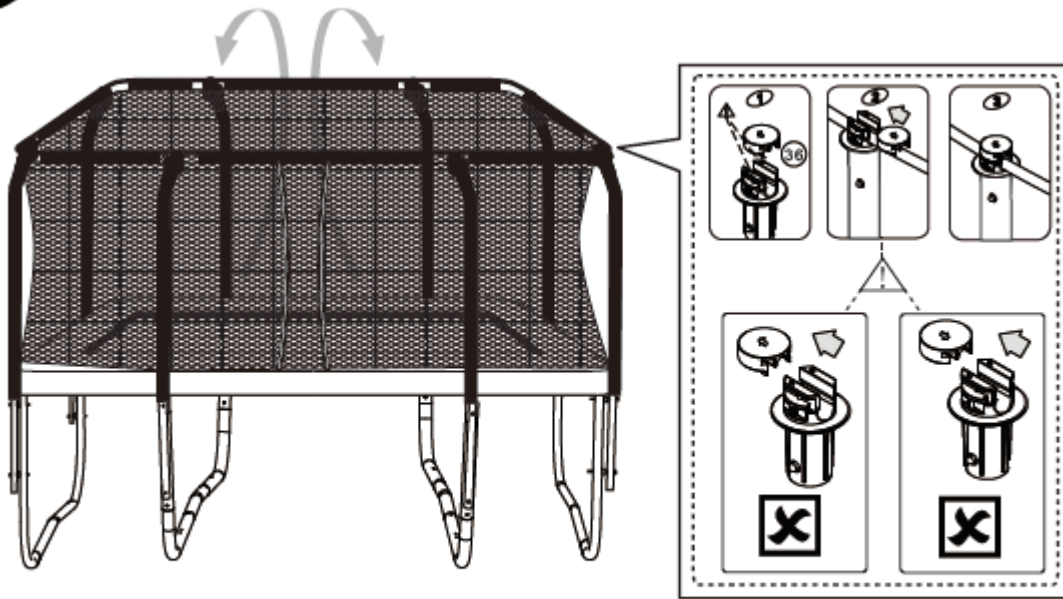

12

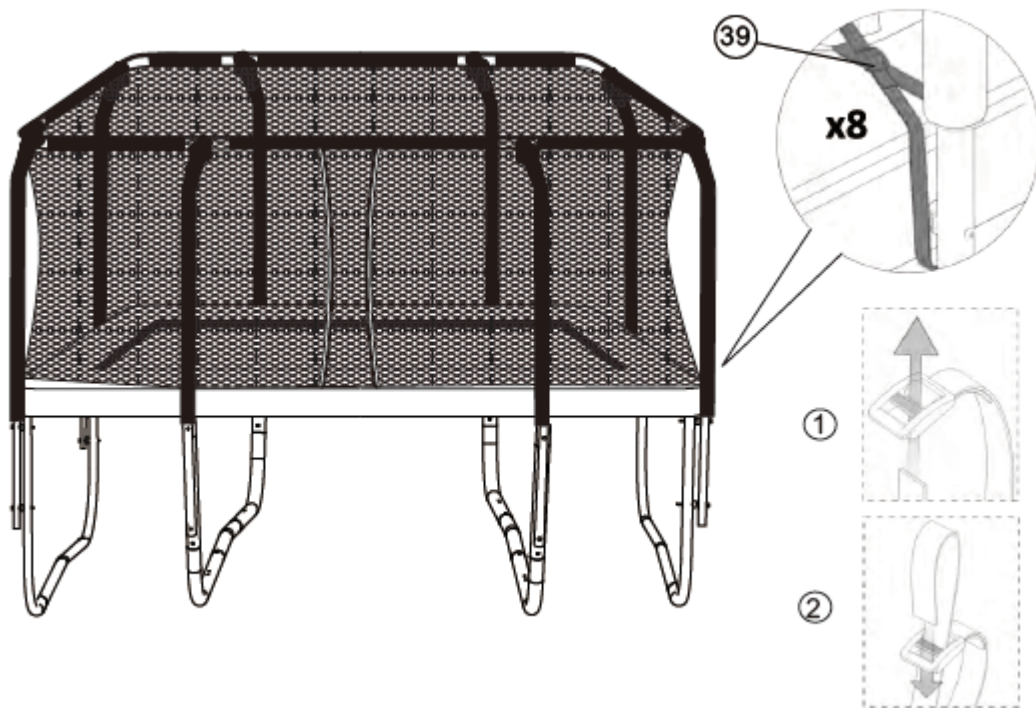

13

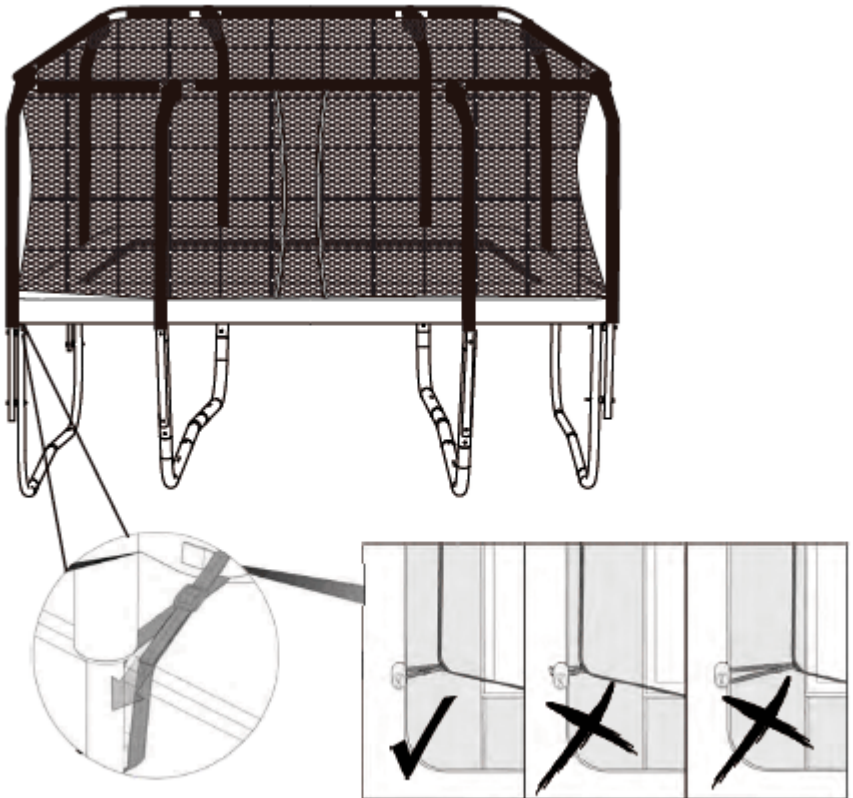

14

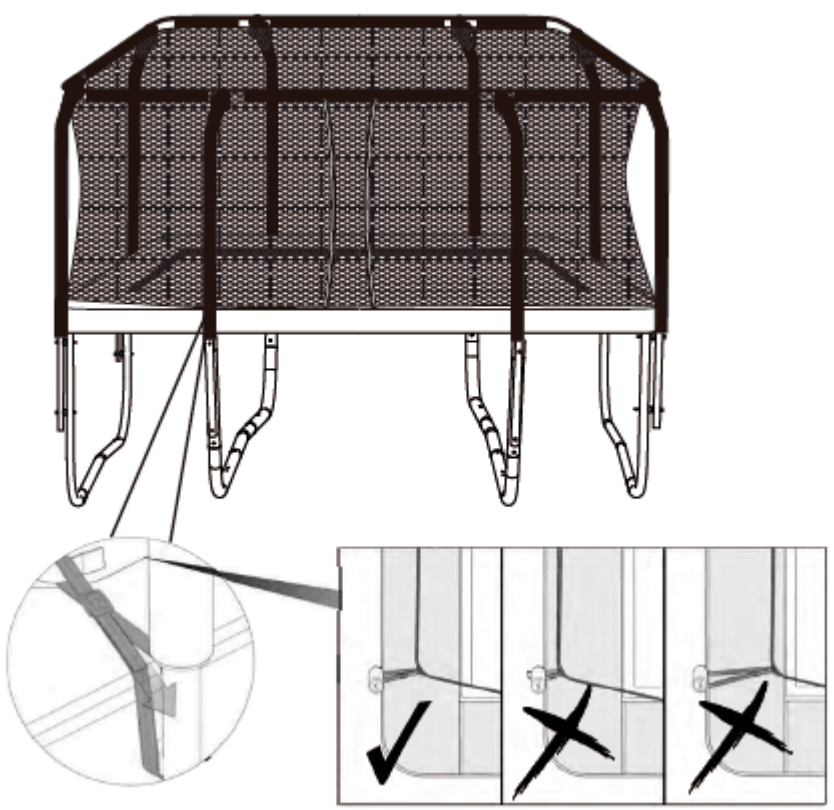

15

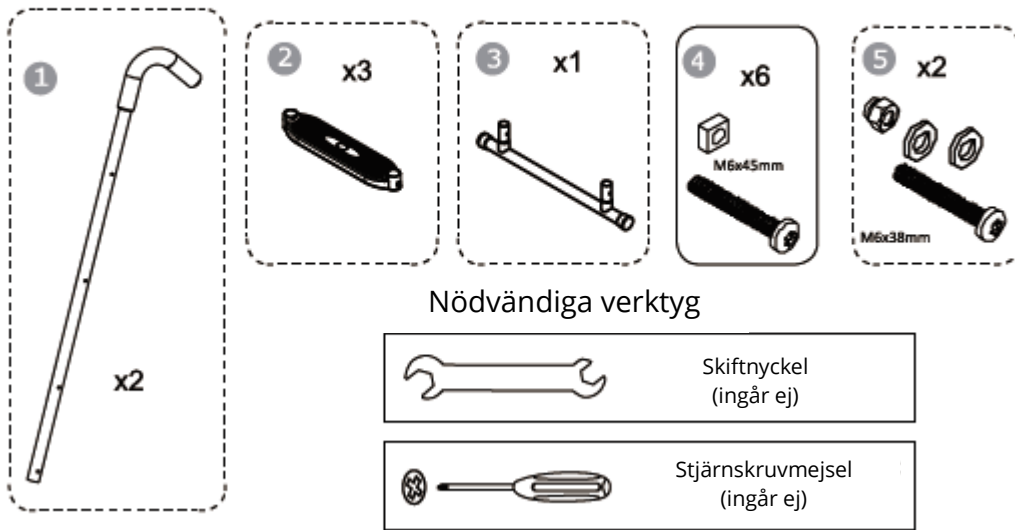

Viktig information:

Studsmattan och tillhörande nät bör packas ner på vintern. Se till att alla delar är torra när de packas undan och förvaras torrt. Var alltid uppmärksam på slitage från väder och vind.

Montering STEGE

16

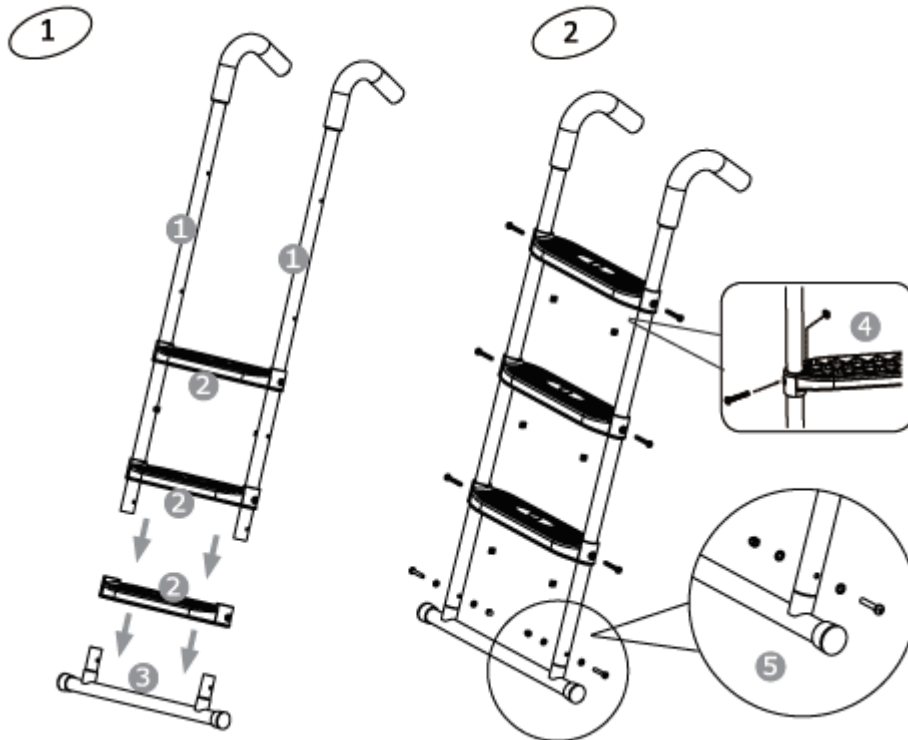

17

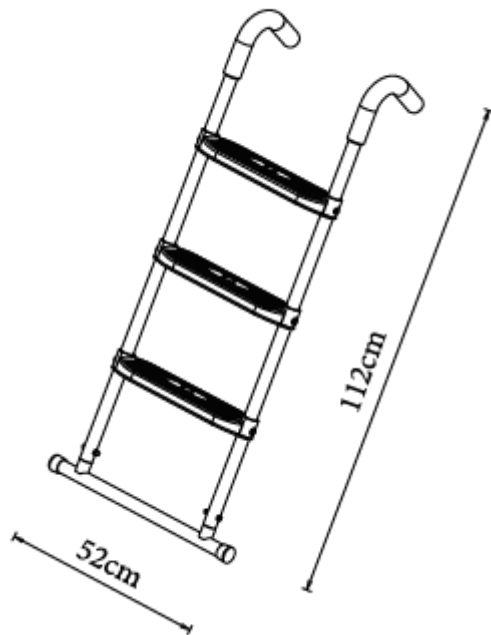

Obs innehåller små delar. Inte lämpligt för barn under 3 år



Viktig information:
Det är viktigt att alla delar som monteras efterspänns efter en veckas bruk, därefter var tredje månad för att vara säker på att studsattan förblir stabil.

18

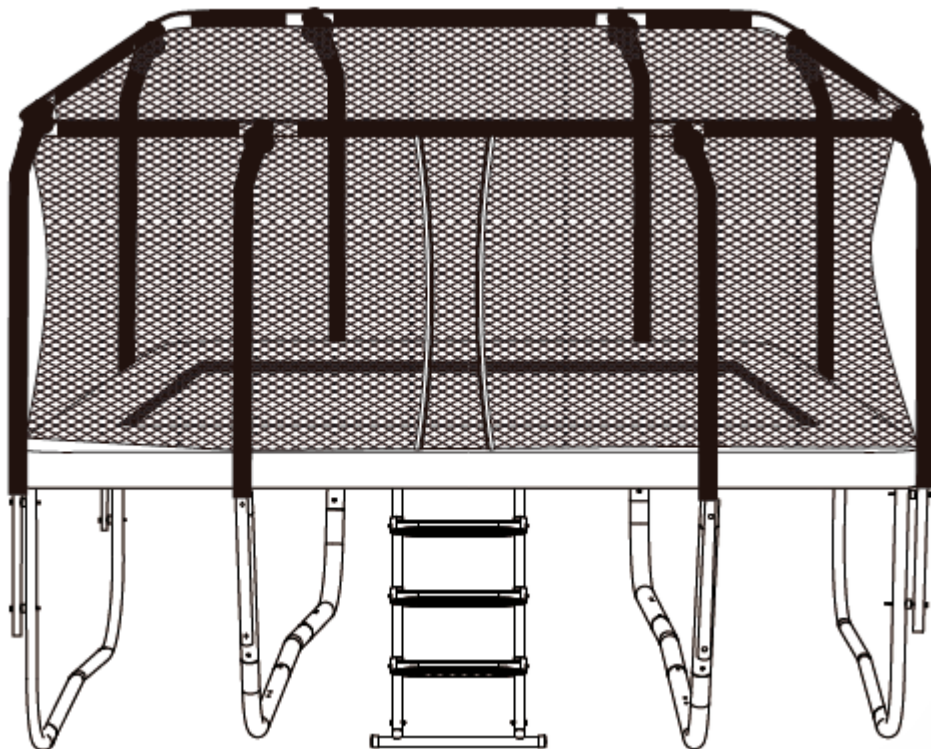

Säkerhetsanvisningar



Inte lämpligt för barn under 3 år att använda studs mattan

Trampolinen är avsedd för privat bruk och ska användas utomhus.
Max belastning är 160kg.

Ägaren är ansvarig för att se till att alla användare är tillräckligt informerade om alla varningar och använder studs mattan rätt!



VARNINGAR

- Det är inte tillåtet för barn att använda studs mattan utan uppsikt av vuxen/kunnig person.
- Studs mattan är avsedd för en person!
- Hoppa aldrig två personer samtidigt! Det ökar risken för skador; allvarliga skador som fraktur i nacken, förlamning mm.
- Inga volter! Det ökar risken för att landa på huvudet eller nacken, vilket kan orsaka allvarliga skador - till och med dödsfall.
- Använd inte studs mattan utan att vila emellanåt.
- Var noga med att hoppa i mitten av duken. Det kan orsaka skada om du träffar en kantdyna, den är inte utformad för att hoppa eller trampa på.
- Var försiktig när du går ut på studs mattan för att undvika att fastna i fjädrarna eller stöta i ramen. Ha alltid ramskyddet placerat korrekt så att det täcker ramen och fjädrar för att undvika skador. Inte hoppa från studs mattan. Klättra ner försiktigt för att undvika skador.
- Alla användare bör vara medveten om sina egna begränsningar. Risken för allvarliga skador bör tas på allvar. Det är viktigt att böja på knäna vid landning för att uppnå bästa möjliga kontroll. Sikta på mittmarkeringen.
- Det är inte tillåtet att använda studs mattan efter konsumtion av alkohol, droger eller andra berusningsmedel. Det ökar risken för skador.
- Rökning bör undvikas när du använder studs mattan.
- Använd inte studs mattan om du lider av högt blodtryck.
- Använd inte studs mattan om du är gravid. Hoppa aldrig på studs mattan från ett tak eller höjd. Det ökar risken för skador.
- Använd inte studs mattan när den är våt. Springtyg blir halkigt och det ökar risken för att få skador.
- Använd inte studs mattan i starka vindar. Det kan orsaka allvarliga skador.
- Studs mattan ska inspekteras för defekter före användning varje gång. Dra fästet och kontrollera med jämna mellanrum att alla band är bundna korrekt.
- Byt ut slitna eller skadade delar. Defekter måste repareras. Se till att hålla studs mattan fri från alger, jord mm.

- Använd inte skor eller stövlar på studsattan.
- Se till att kläder och fickor inte innehåller vassa föremål när du använder studsattan.
- Låt inte husdjur vara på studsattan. Vassa klor kan skada duken.
- Använd inte studsattan när det är mörkt ute.
- Se till att hålla dragkedjan på nätet stängd när studsattan används.
- Kontrollera att kardborrebanden är ordentligt stängda när studsattan används.
- Kontrollera med jämna mellanrum att nätet är korrekt installerat.
- Studsattan och nätet ska inspekteras för defekter före användning varje gång.
- Defekter måste repareras.
- Innan starten av säsongen bör studsattan underhållas.
- Regelbundet underhåll krävs.
- Kontrollera att alla muttrar och skruvar är åtdragna och dra åt dem vid behov.
- Får endast användas av en person i taget, eftersom det finns en risk för kollision.
- Det är förbjudet att göra volter.
- Ska användas under tillsyn av vuxen.
- Kontrollera att alla skyddslock för skruvar för vassa kanter är utbytta vid behov.
- Ändras ursprunget på mattan (till exempel lägga till tillbehör), bör det utföras i enlighet med tillverkarens instruktioner.



VARNINGAR

Placering av studsattan:

- Det måste finnas minst 7,3 meters frihöjd. Det får inte finnas några föremål i detta område.
- Studsattan bör placeras på en plan yta.
- Ytan får inte vara sten, betong eller asfalt.
- Det får inte finnas några hinder under studsattan.
- Studsattan bör placeras på lämpligt avstånd (minst 2,5 m) från elektriska ledningar, pooler, staket, träd och grenar, leksaker eller andra föremål.

Underhåll:

Rengöring av duken bör ske med fuktig trasa för att avlägsna alger, smuts mm. Torka efter med en torr trasa. Använd inte studsattan förrän den är torr igen. Användning av rengöringsmedel eller andra kemikalier är inte tillåtna för rengöring av produkten. Dra med jämna mellanrum åt alla kopplingar och kontrollera att skyddsmatta är korrekt monterad.

Ytterligare information:

Det rekommenderas att stormsäkra studsattan mot starka vindar. Surra fast studsatta med rep som fäster studsattans ram. Använd minst 3 rep jämnt fördelade över studsattans ram. Fästa inte bara benen, eftersom dessa kan dras krokiga och förstöra studsattan. Alternativet är att demontera eller ta bort trampolin helt och hållet. Det kan orsaka stor fara om studsattan inte är säkrad i starka vindar.



VARNINGAR

- Säkerhetsnätet ska bytas efter två år
- Säkerhetsnätet ska stängas innan man påbörjar hoppa i studs mattan.
- Det är inte tillåtet att äta samtidigt som man hoppar i studs mattan
- Studsmattan är inte beräknad till att grävas ned i jorden.
- I vissa länder kan snövikten och de mycket låga temperaturerna på vintern skada studs mattan. Vi rekommenderar att du tar bort snön och förvarar mattan och skyddsnätet inomhus.

Instruktioner om hur man ska hoppa på studsmattan



EU-Försäkran om överensstämmelse

| | |
|---|--|
| EU-FÖRSÄKRAN OM ÖVERENSSTÄMMELSE  | |
| EU – importör: | P. Lindberg A/S Sdr. Ringvej 1 DK-6600 Vejen Tlf.: +45 70212626 E-mail: salg@p-lindberg.dk CVR: 25903110 www.p-lindberg.dk |
| Härmed förklara att följande maskin: | <i>Fyrkantig studsatta 512 x 305 cm. PL art. 9062850</i> |
| Type / modell: | <i>TATR-1017BR</i> |
| Överensstämmer med följande direktiv: | <i>2009/48/EC</i> |
| Tillämpade standarder och normer: | <i>EN 71-1:2014 + A1:2018 EN 71-2:2011+A1:2014 EN 71-14:2018 EN 71-3:2019</i> |
| Datum och signatur: | <i>Vejen d.16-11-2020</i> P. Lindberg A/S  Erik T Lauritsen Direktør  |

Vi förbehåller oss rätten utan förvarning ändra tekniska parametrar och specifikationer för denna produkt

DE SICHERHEITSANWEISUNGEN UND MONTAGEANLEITUNG



Trampolin, viereckig – Artikel-Nr. 9062850

Beschreibung: Viereckiges Trampolin mit Netz, Matten und Leiter. 518 x 305 cm.

Inhalt

| | |
|---|----|
| Einleitung:..... | 1 |
| Inhalt Box 1..... | 3 |
| Inhalt Box 2..... | 3 |
| Inhalt Box 3..... | 4 |
| Montageanleitung RAHMEN: | 5 |
| Montageanleitung NETZ:..... | 10 |
| Montageanleitung LEITER: | 16 |
| Sicherheitsanweisungen:..... | 18 |
| Abbildung verschiedener Springübungen | 21 |
| EU-Konformitätserklärung..... | 22 |

Einleitung:

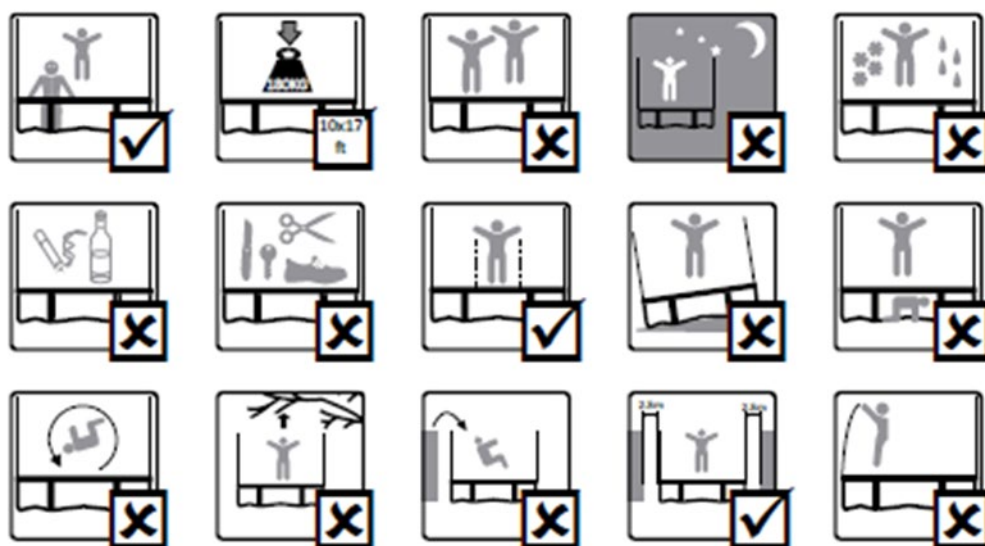

Detaillierte Sicherheitsanweisungen finden Sie am Ende dieser Anleitung.

Lesen Sie sämtliche Sicherheitsanweisungen sowie die gesamte Montageanleitung vor der Verwendung sorgfältig und bewahren Sie diese zum Nachschlagen für später auf.

Es wird empfohlen, dass mindestens zwei Personen das Trampolin zusammenbauen. Das Trampolin muss von einem Erwachsenen laut Montageanleitung zusammengebaut werden und ist vor dem erstmaligen Gebrauch zu überprüfen.

Für den Transport des Trampolins werden mindestens zwei Personen benötigt. Heben Sie das Trampolin vorsichtig an, halten Sie es waagrecht und ziehen Sie das Trampolin an den gewünschten Ort.

Soll das Trampolin weiter transportiert werden, sollte es abgebaut und erneut aufgebaut werden, um es nicht zu beschädigen.

Wird das Trampolin über längere Zeit nicht benutzt, muss es abgebaut und weggepackt werden. An einem trockenen Ort aufbewahren.



Wichtige Information: Lesen Sie vor dem Aufbau und/oder der Verwendung dieses Produkts die Bedienungsanleitung sorgfältig. Beachten Sie die Anweisungen der Bedienungsanleitung genau und bewahren Sie diese für später auf.



Wichtige Information: Es ist wichtig, dass alle Produkte, die mit Schrauben jeglicher Art zusammengebaut werden, zwei Wochen nach dem Zusammenbau sowie alle drei Monate nachgezogen werden, damit das Produkt während seiner Lebensdauer seine Stabilität beibehält.

Inhalt Box 1

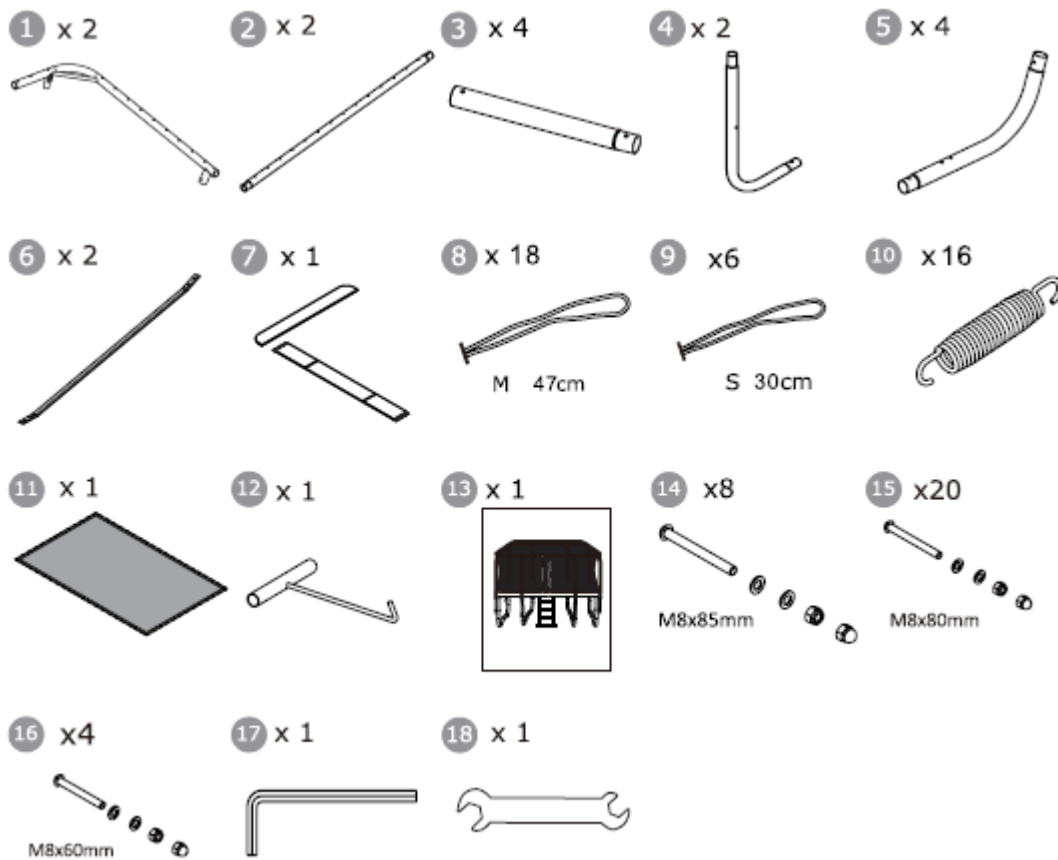

Inhalt Box 2

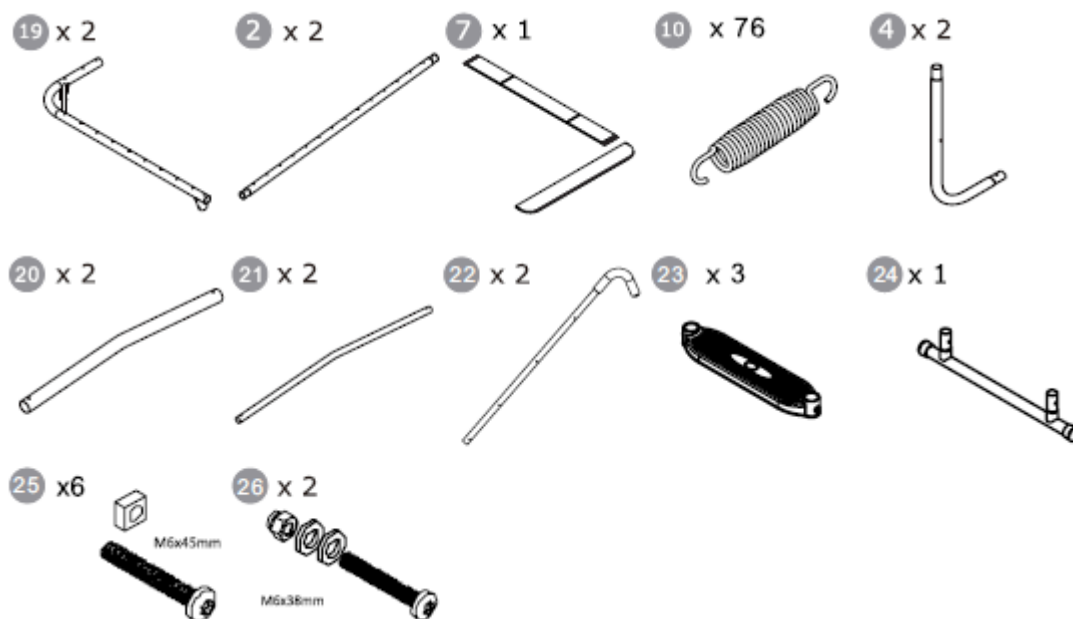

Inhalt Box 3

27 x 8



28 x 4

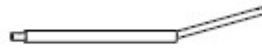

29 x 4



30 x 1



31

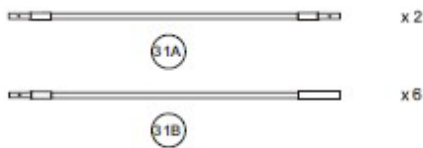

32



33 x 8



34 x 8

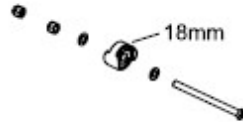

35 x 8



36 x 8



37 x 8



38 x 4



39 x 8



Montageanleitung RAHMEN: Komponenten:

1 x 2



2 x 4



3 x 4



4 x 4



5 x 4



6 x 2



7 x 1

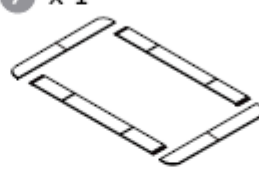

10 x 92



11 x 1

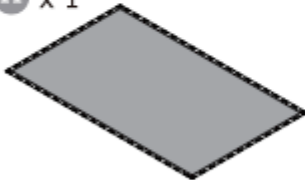

12 x 1



14 x 8

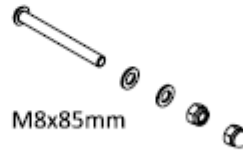

15 x 20

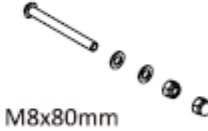

16 x 4



17 x 1



18 x 1



19 x 2



20 x 2



21 x 2



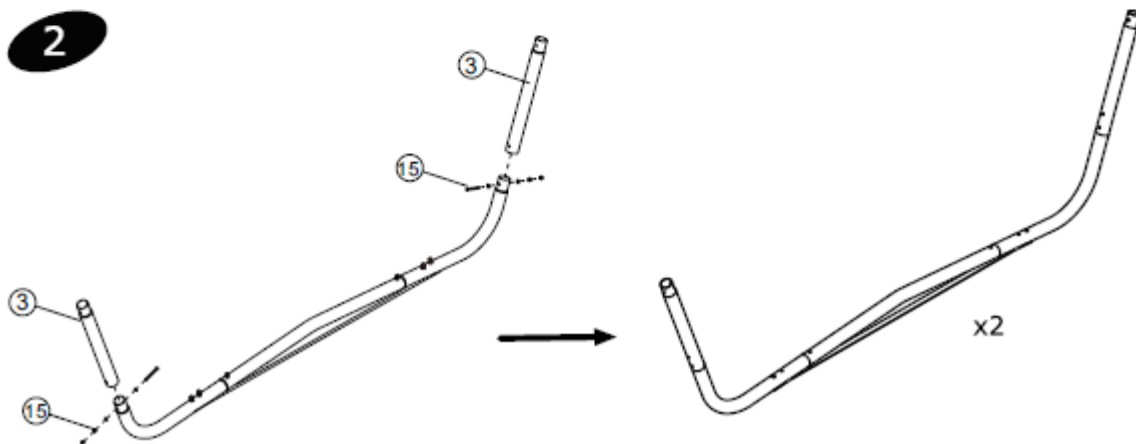
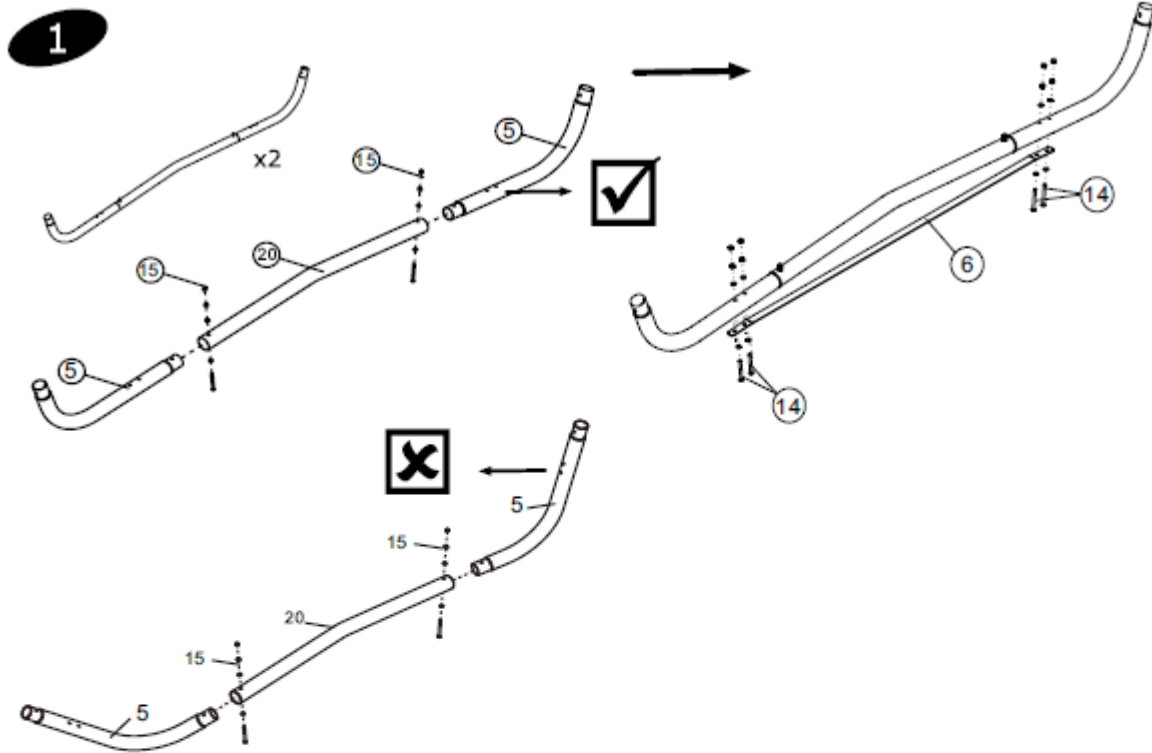

3

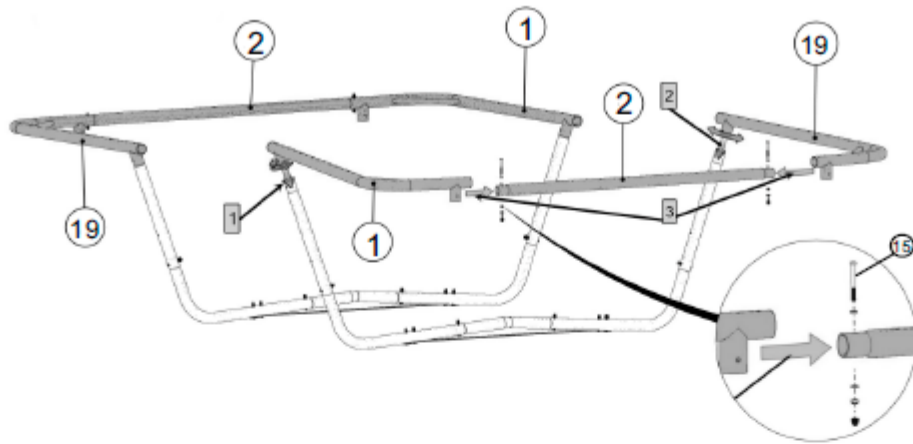

4

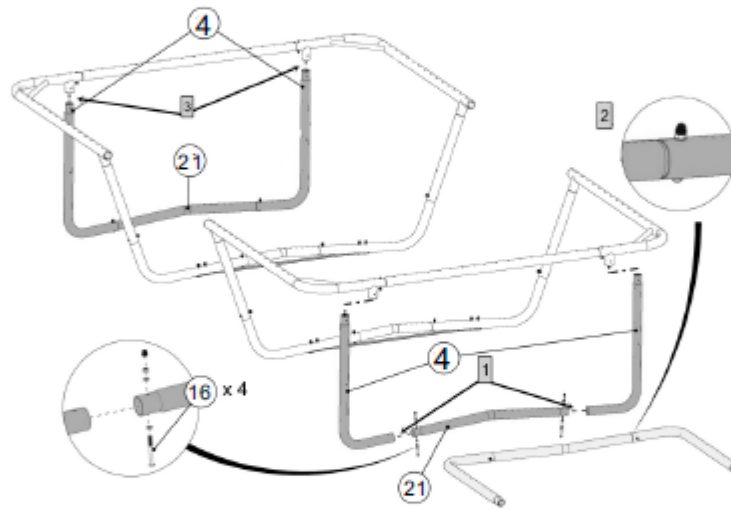

5

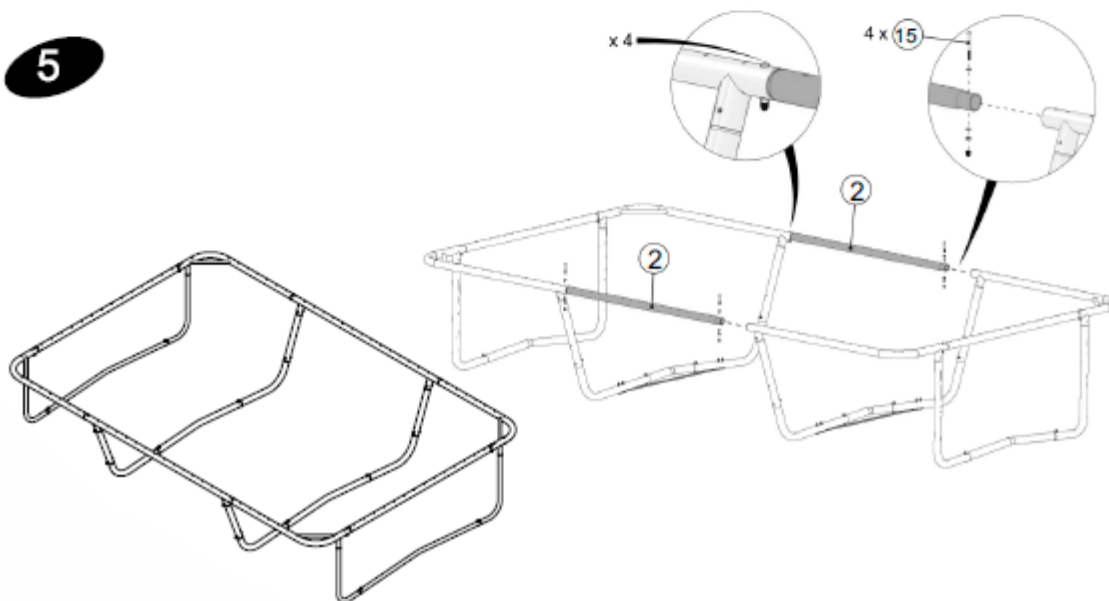

6

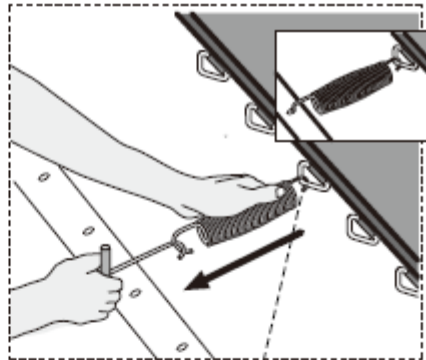
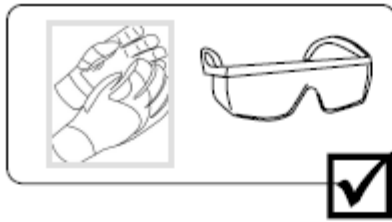

x92



1

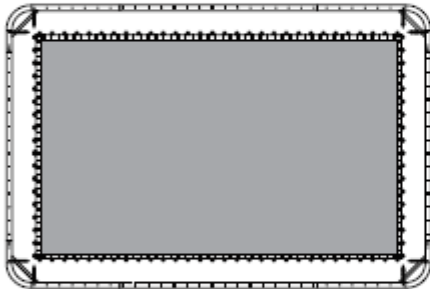

2



3

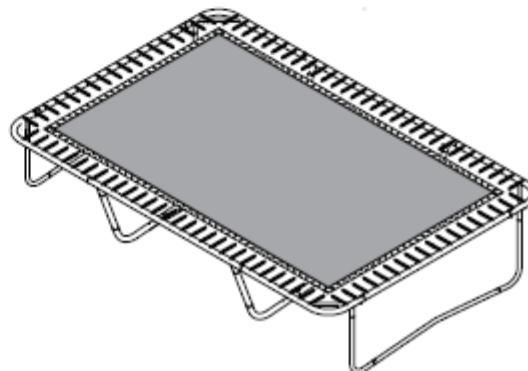
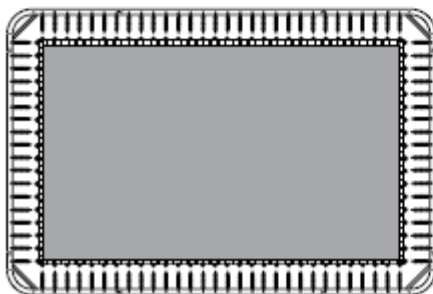

7

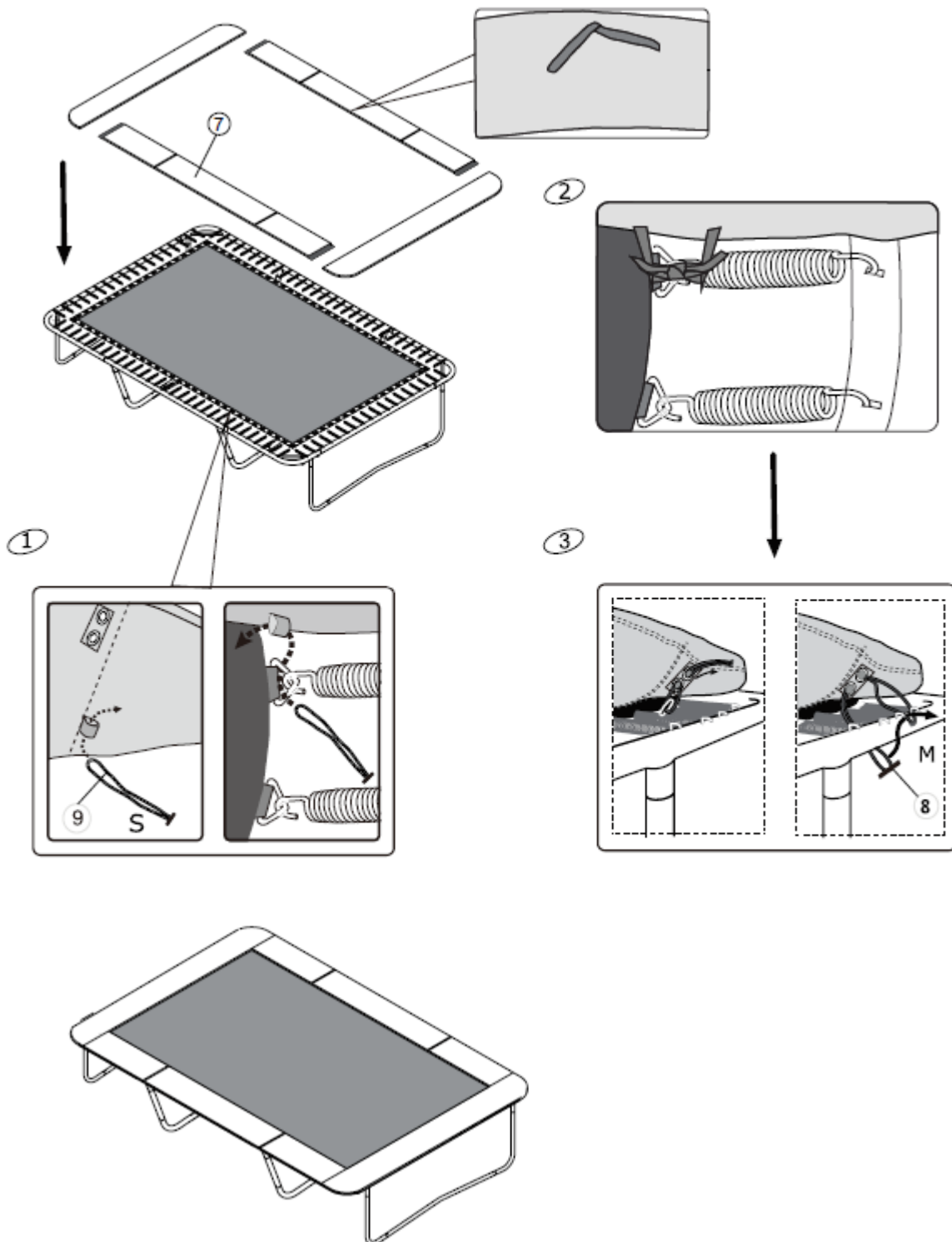

Montageanleitung NETZ:

27 x 8



28 x 4



29 x 4



30 x 1

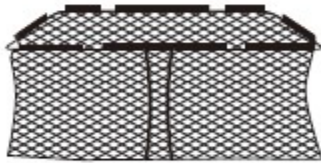

31

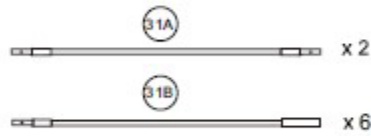

32



33 x 8



34 x 8

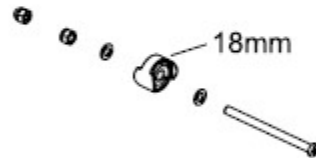

35 x 8



36 x 8



37 x 8



38 x 4



39 x 8



17 x 1



18 x 1





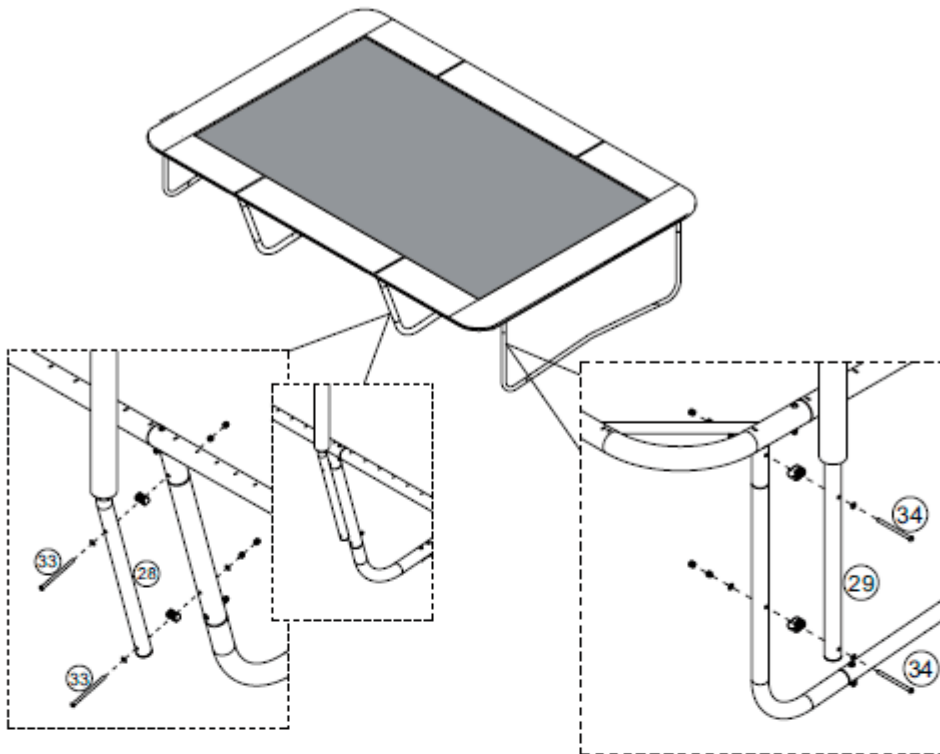

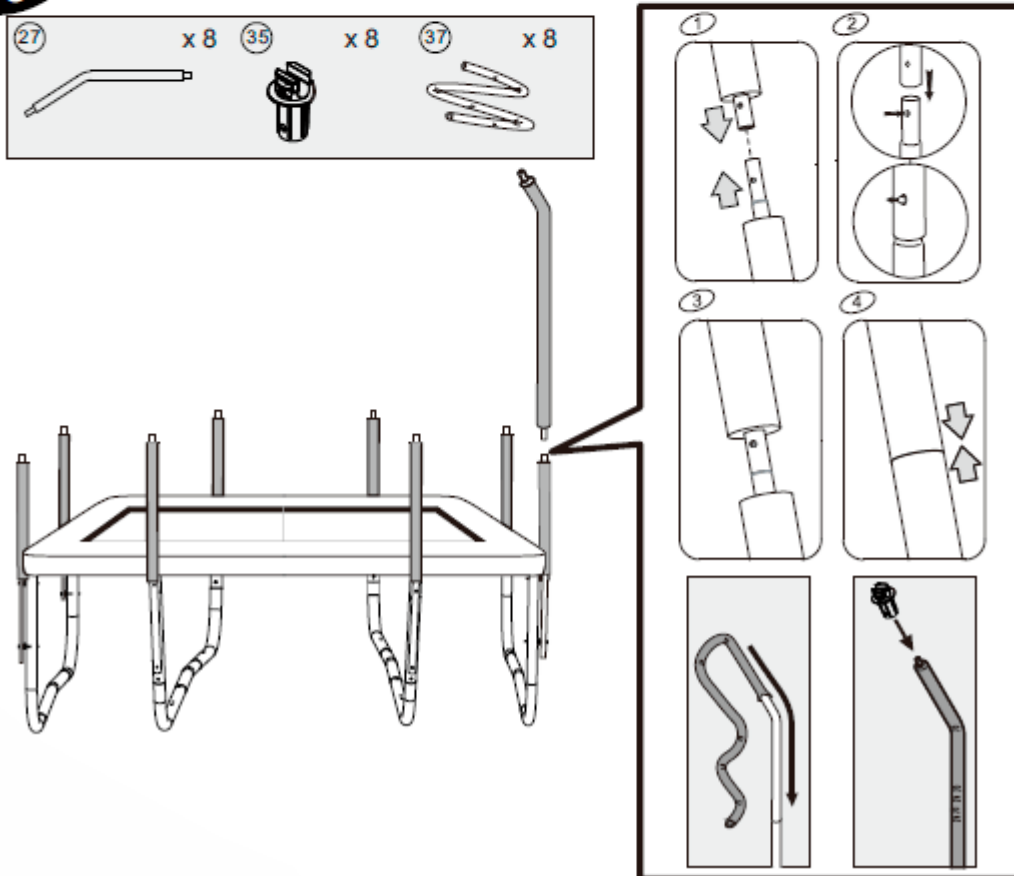

8



9



10

- 31A  x 2 31B  x 4
- 32A  x 2 32B  x 6
- 30  x 1 38  x 4 39  x 8

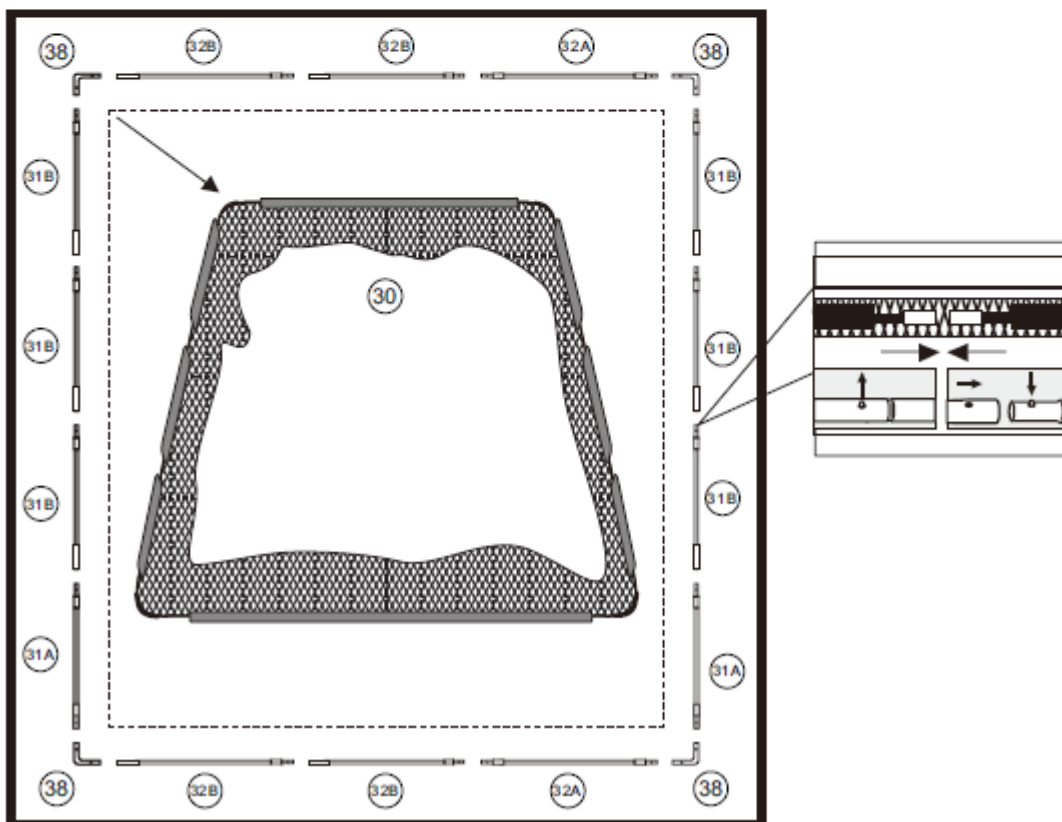
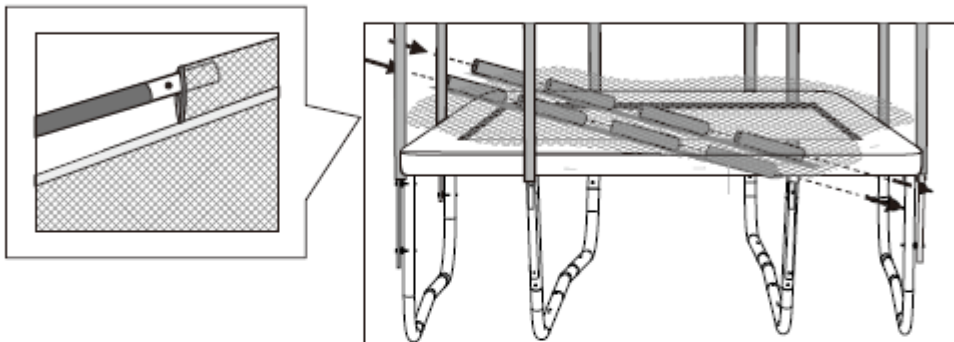

11

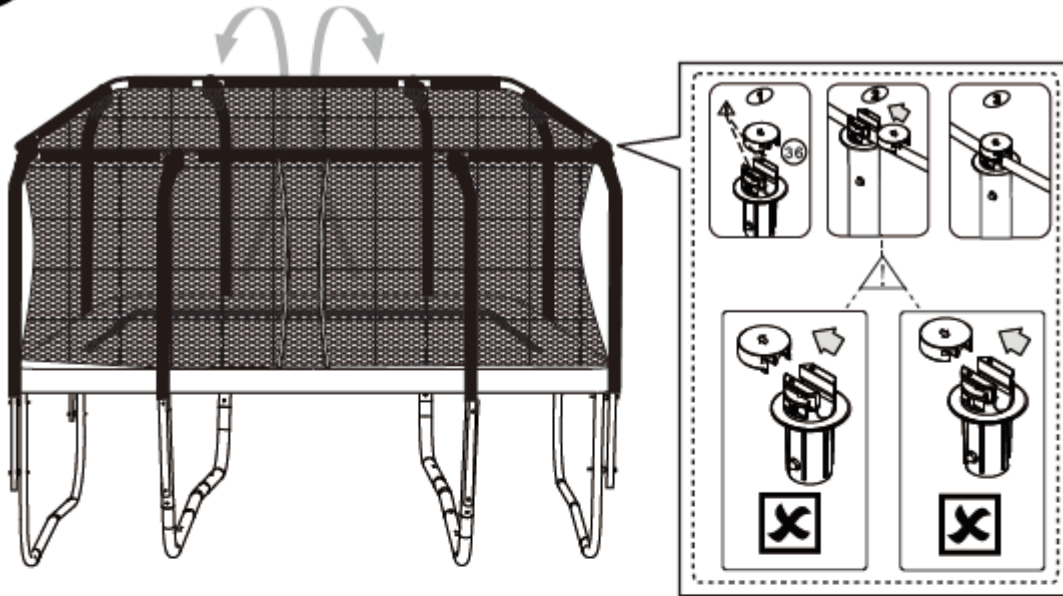

12

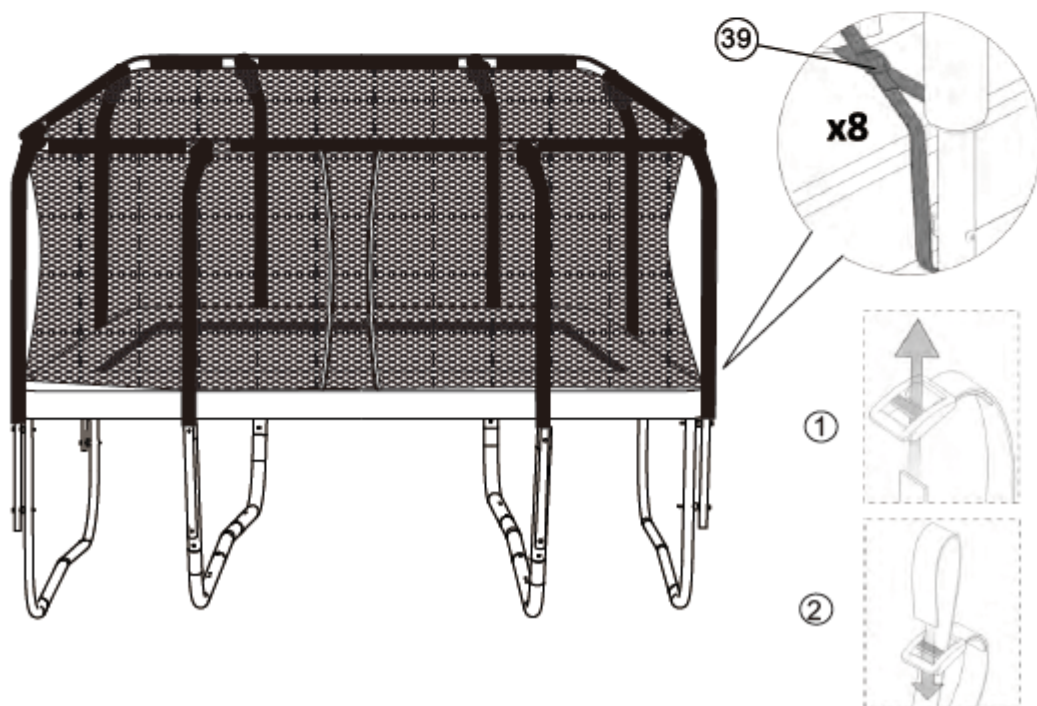

13

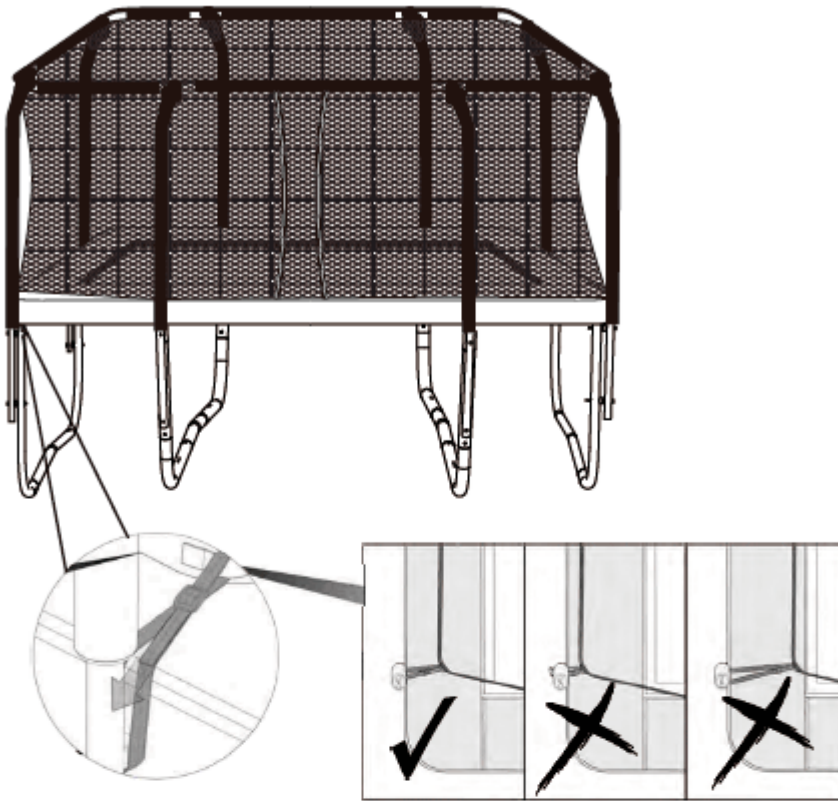

14

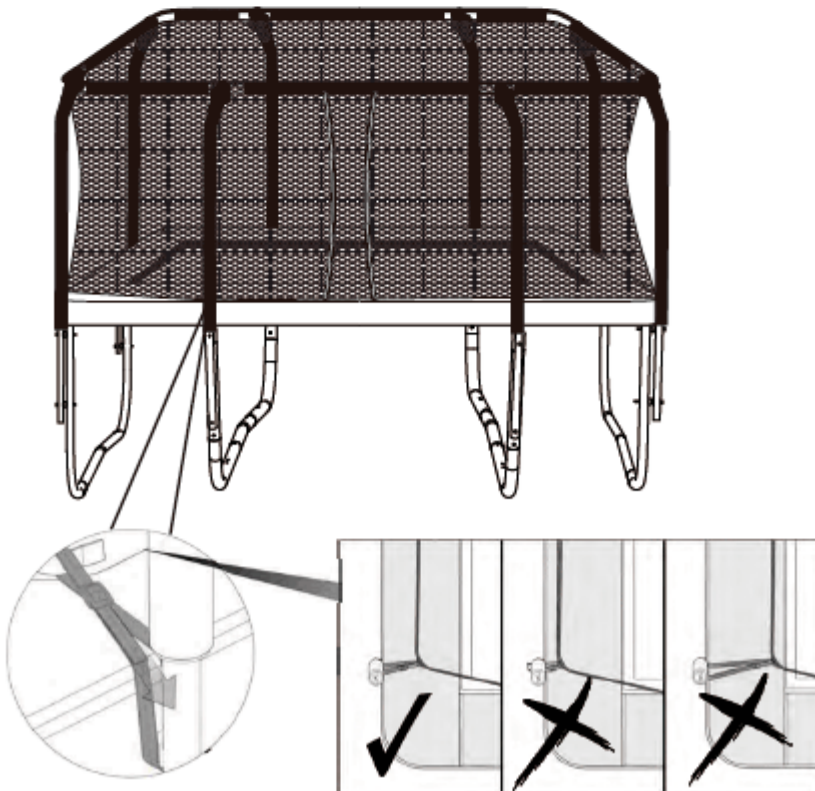

15

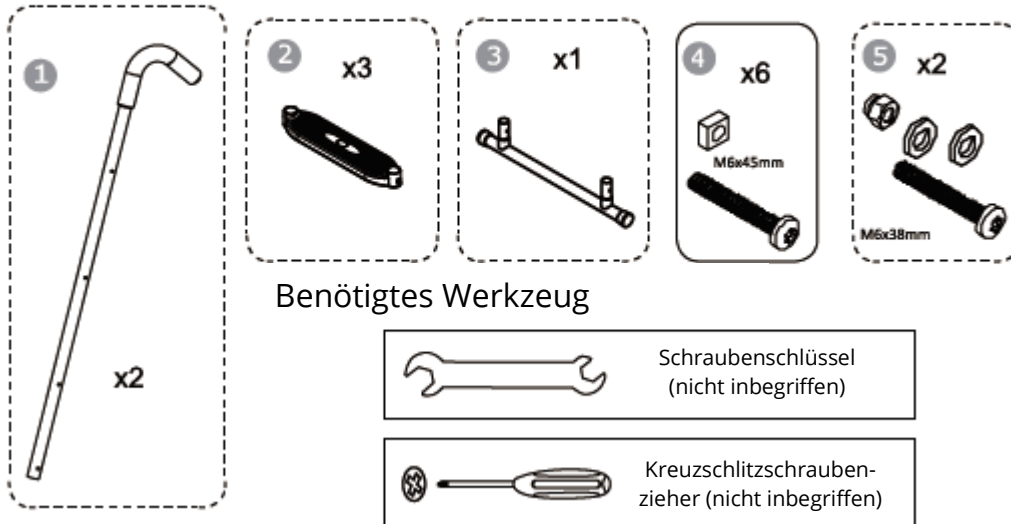

Wichtige Information:
 Trampolin und Netz sollten im Winter weggepackt werden. Sorgen Sie dafür, dass alle Teile trocken und sorgfältig eingepackt sind. Trocken lagern. Achten Sie stets auf Abnutzungen durch Wind und Wetter.

Montageanleitung LEITER:

16

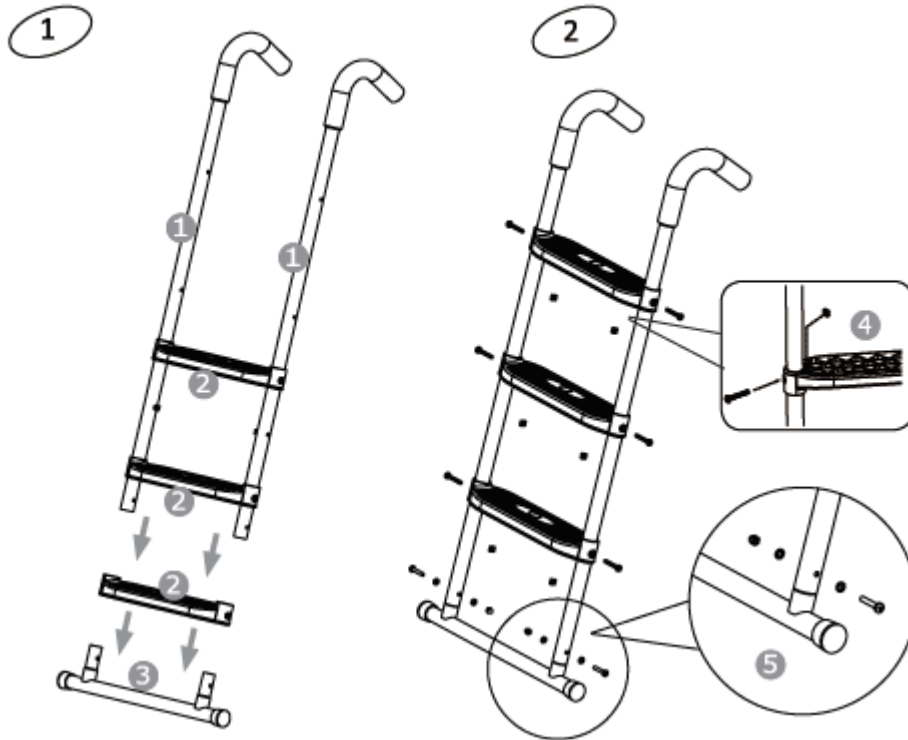

17

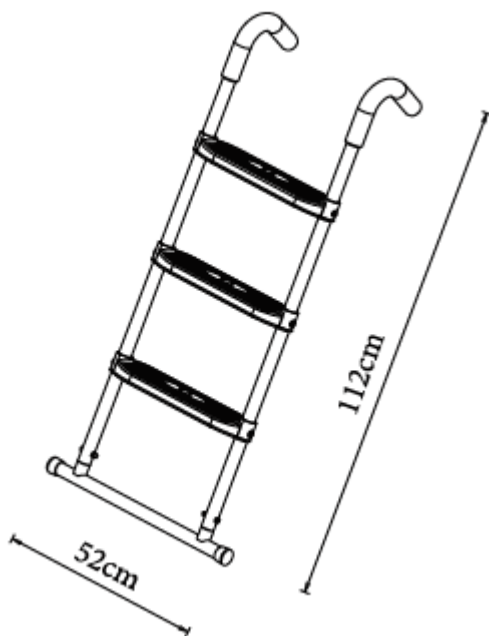

Achtung: Enthält Kleinteile. Nicht für Kinder unter drei Jahren geeignet.



Wichtige Information:

Es ist wichtig, dass alle Produkte, die mit Schrauben jeglicher Art zusammengebaut werden, zwei Wochen nach dem Zusammenbau sowie alle drei Monate nachgezogen werden, damit das Produkt während seiner Lebensdauer seine Stabilität beibehält.

18

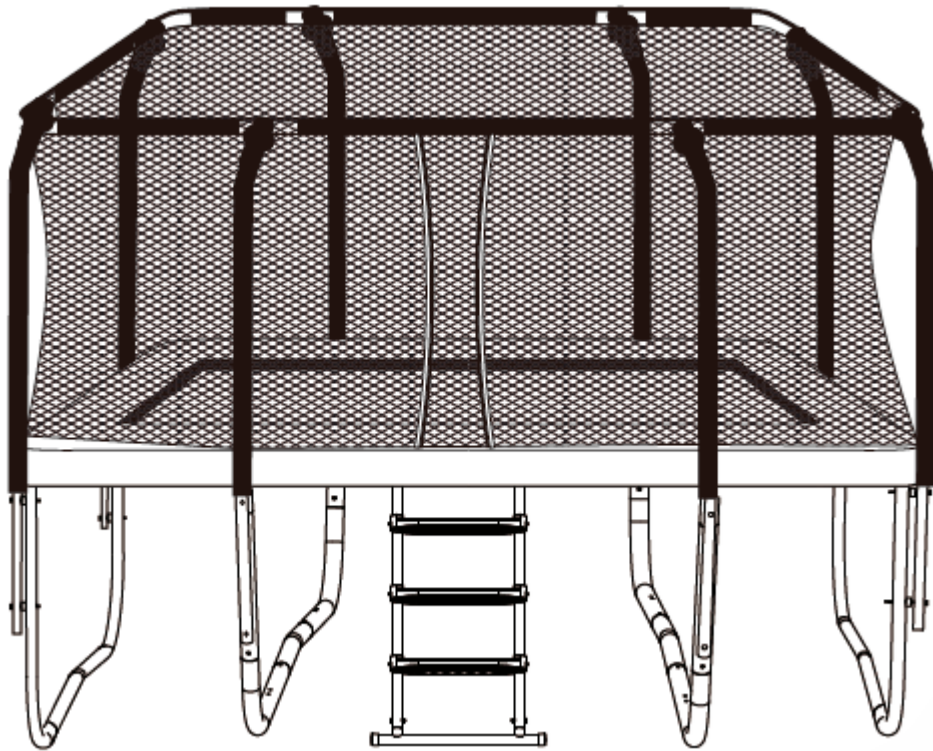

Sicherheitsanweisungen:



Nicht für Kinder unter 3 Jahren geeignet, da sie das Trampolin noch nicht richtig benutzen können.

Dieses Trampolin ist für die private Verwendung, ausschließlich im Freien, gedacht.
Max. Belastung 160 kg.

Der Eigentümer bzw. die Aufsichtsperson trägt die Verantwortung dafür, dass alle Benutzer über sämtliche Sicherheitsanweisungen und die korrekte Verwendung Bescheid wissen!



WARNUNGEN

- Die Benutzung des Trampolins ohne Aufsicht einer erwachsenen, darüber informierten Person, ist verboten.
- Das Trampolin darf jeweils nur von 1 Person benutzt werden. Das Trampolin ist nur für 1 Person ausgelegt!
- Es dürfen nie 2 Personen gleichzeitig springen! Dies erhöht die Verletzungsgefahr sowie die Gefahr für schwere Unfälle wie Genickbruch, Lähmungen usw.
- Das Schlagen von Saltos ist verboten! Dadurch erhöht sich die Gefahr, auf Kopf oder Nacken zu landen, was schwere Verletzungen – schlimmstenfalls den Tod – zur Folge haben kann.
- Das Trampolin nicht über lange Zeit benutzen (Pausen einlegen).
- Vergewissern Sie sich, dass Sie mittig auf der Sprungfläche springen. Wenn Sie am Randpolster aufkommen, kann dies zu Verletzungen führen, da dieser keineswegs dazu gedacht ist, darauf zu treten oder zu hüpfen.
- Seien Sie vorsichtig, wenn Sie auf das Trampolin steigen, sodass Sie sich nicht an den Federn klemmen oder am Rahmen stoßen.
- Sorgen Sie stets dafür, dass das Randpolster korrekt sitzt sowie Rahmen und Federn bedeckt, um Verletzungen zu vermeiden. Springen Sie nie vom Trampolin herunter. Klettern Sie vorsichtig herunter, damit Sie sich nicht verletzen.
- Alle Nutzer müssen sich über ihre eigenen Begrenzungen im Klaren sein. Die Gefahr schwerer Verletzungen muss ernst genommen werden. Es ist wichtig, beim Landen tief in die Knie zu gehen, um die bestmögliche Kontrolle zu behalten. Springen und landen Sie an derselben Stelle – so behält man am besten die Kontrolle. Orientieren Sie sich an der Mittelmarkierung. Erreichen Sie die volle Kontrolle über die Sprünge, bevor schwierigere Sprünge trainiert werden.
- Die Nutzung des Trampolins ist nach Alkoholgenuss, Einnahme von Medikamenten oder anderen euphorisierenden Stoffen verboten. Dies erhöht das Verletzungsrisiko erheblich, da Koordinationsfähigkeit, Urteilsfähigkeit und Reaktionszeit beeinträchtigt werden.
- Bei der Verwendung des Trampolins ist das Rauchen strengstens verboten.

- Verwenden Sie das Trampolin nicht, wenn Sie an hohem Blutdruck leiden.
- Verwenden Sie das Trampolin nicht, wenn Sie schwanger sind. Springen Sie niemals vom Dach oder anderen erhöhten Punkten auf das Trampolin. Dies erhöht die Verletzungsgefahr.
- Ziehen Sie sich nicht mithilfe des Randpolsters auf das Trampolin.
- Verwenden Sie das Trampolin nicht, wenn es nass ist. Die Sprungfläche wird glatt, wodurch sich das Risiko erhöht, dass der Springer fällt und sich verletzt.
- Verwenden Sie das Trampolin nicht bei starkem Wind. Dadurch kann der Springer die Kontrolle verlieren, was ernsthafte Verletzungen zur Folge haben kann.
- Das Trampolin muss JEDES Mal vor der Verwendung auf Mängel überprüft werden. Ziehen Sie den Beschlag nach und kontrollieren Sie regelmäßig, ob alle Bänder richtig gebunden sind.
- Tauschen Sie abgenutzte und defekte Teile aus. Mängel müssen behoben werden. Halten Sie das Trampolin frei von Algen, Erde usw.
- Auf dem Trampolin dürfen keine Schuhe, Stiefel oder sonstiges Schuhwerk getragen werden.
- Sorgen Sie dafür, dass Kleidung und Taschen keine scharfen Gegenstände bei der Verwendung des Trampolins beinhalten.
- Lassen Sie keine Haustiere auf das Trampolin. Scharfe Krallen können die Sprungfläche beschädigen.
- Wird eine Leiter zum Hinauf- und Heruntersteigen vom Trampolin verwendet, achten Sie bitte besonders darauf, dass das Trampolin nicht ohne Aufsicht verwendet wird! Entfernen Sie evtl. die Leiter.
- Benutzen Sie das Trampolin nicht nach Einbruch der Dunkelheit.
- Sorgen Sie dafür, dass der Reißverschluss am Netz geschlossen bleibt, wenn das Trampolin verwendet wird. Beachten Sie bitte, dass das Netz nicht dafür konstruiert wurde, hineinzuspringen, um mehr Geschwindigkeit und einen schnelleren Absprung zu erreichen!
- Sorgen Sie dafür, dass die Klettverschlüsse korrekt geschlossen sind, wenn das Trampolin verwendet wird.
- Kontrollieren Sie regelmäßig, ob das Netz richtig montiert ist. Montagebeschläge festziehen.
- Trampolin und Netz müssen JEDES Mal vor der Verwendung auf Mängel überprüft werden. Ziehen Sie den Beschlag nach und kontrollieren Sie regelmäßig, ob alle Bänder richtig gebunden sind. Tauschen Sie abgenutzte und defekte Teile aus. Mängel müssen behoben werden.
- Vor Saisonbeginn muss das Trampolin gewartet werden.
- Eine regelmäßige Wartung ist notwendig. Wird die Wartung nicht regelmäßig durchgeführt, kann dies eine Gefahr für die Benutzer bedeuten.
- Überprüfen Sie, ob alle Muttern und Schrauben fest angezogen sind und spannen Sie diese bei Bedarf nach.
- Überprüfen Sie, dass alle federbelasteten (Stift-)Verbindungen intakt sind, sodass sie sich nicht während des Spielens lösen können.
- Darf jeweils nur von einer Person genutzt werden, da die Gefahr des Zusammenstoßes besteht.
- Das Schlagen von Saltos ist untersagt.
- Darf nur unter Aufsicht Erwachsener verwendet werden.
- Alle Schutzkappen für Bolzen auf scharfe Kanten überprüfen, und wenn nötig austauschen.
- Änderungen, die der Benutzer selbst am ursprünglichen Trampolin vornimmt (beispielsweise das Hinzufügen von Zubehör) müssen gemäß den Anweisungen des Herstellers vorgenommen werden.



WARNUNGEN:

Aufstellen des Trampolins:

- Die lichte Höhe muss mindestens 7,3 m betragen. In diesem Bereich dürfen sich keinerlei Gegenstände befinden.
- Stellen Sie das Trampolin auf eine ebene Oberfläche.
- Die Unterlage darf nicht aus Beton, Fliesen oder Asphalt bestehen.
- Unter dem Trampolin dürfen keinerlei Gegenstände liegen.
- Das Trampolin muss in einem angemessenen Abstand (mindestens 2,5 m) zu Stromleitungen, Schwimmbecken, Hecken, Bäumen, Ästen, Klettergerüsten und anderen Gegenständen aufgestellt werden.

Wartung:

Die Reinigung der Sprungfläche erfolgt mit einem feuchten Tuch. Algen, Schmutz usw. werden entfernt. Trocknen Sie mit einem trockenen Tuch nach. Verwenden Sie das Trampolin nicht, bevor es wieder ganz trocken ist. Für die Reinigung des Produkts dürfen keine Reinigungsmittel oder andere Chemikalien verwendet werden. Ziehen Sie alle Beschläge regelmäßig nach und überprüfen Sie, ob die Schutzmatte richtig montiert ist.

Zusätzliche Informationen:

Es wird empfohlen, das Trampolin bei starkem Wind zu sichern. Das Trampolin mit Seilen sichern, die an den Rahmen des Trampolins befestigt werden. Mindestens drei Sicherungen gleichmäßig verteilt über den Rahmen des Trampolins verwenden. Sichern Sie nicht nur die Beine, da sich diese verziehen können, wodurch das Trampolin beschädigt werden kann. Bauen Sie das Trampolin evtl. ganz ab und entfernen Sie es. Es kann äußerst gefährlich sein, das Trampolin bei starkem Wind nicht zu sichern.



WARNUNGEN:

- Das Sicherheitsnetz ist nach zwei Jahren auszuwechseln.
- Das Sicherheitsnetz muss geschlossen werden, bevor das Trampolin benutzt wird.
- Beim Springen auf dem Trampolin ist es nicht gestattet, gleichzeitig zu essen.
- Das Trampolin ist nicht dafür ausgelegt, in den Erdboden eingegraben zu werden.
- Im Winter kann in einigen Ländern das Gewicht von herabgefallenem Schnee sowie die sehr niedrigen Temperaturen das Trampolin beschädigen. Es wird deshalb empfohlen, den Schnee stets zu entfernen und die Matte und das Sicherheitsnetz im Innenbereich aufzubewahren.

Abbildung verschiedener Springübungen



EU-Konformitätserklärung

| | | |
|--|---|-----------|
| EU-KONFORMITÄTSERKLÄRUNG | | CE |
| EU – importeur: | P. Lindberg A/S Sdr. Ringvej 1 DK-6600 Vejen Tlf.: +45 70212626 E-mail: salg@p-lindberg.dk CVR: 25903110 www.p-lindberg.dk | |
| Hiermit wird bestätigt dass die folgenden Maschine:: | Viereckiges Trampolin 512 x 305 cm. PL Artikelnummer 9062850 | |
| Typ / Modell: | TATR-1017BR | |
| Entspricht den folgenden Richtlinien: | 2009/48/EC | |
| Angewandte Standards und Normen: | EN 71-1:2014 + A1:2018 EN 71-2:2011+A1:2014 EN 71-14:2018 EN 71-3:2019 | |
| Datum und Unterschrift: | Vejen d. 16-11-2020 | |
| |  Erik T Lauritsen Direktør | CE |

Wir behalten uns das Recht vor, ohne vorherige Information technische Parameter oder Spezifikationen für dieses Produkt zu ändern.

EN SAFETY INSTRUCTIONS & ASSEMBLY GUIDE



Trampoline – Item no. 9062850

Description: Square trampoline with net, mats and ladder. 518 x 305 cm.

Content

| | |
|--|----|
| Introduction:..... | 1 |
| Content box 1..... | 3 |
| Content box 2..... | 3 |
| Content box 3..... | 4 |
| Assembly instruction, FRAME:..... | 5 |
| Assembly instruction NET:..... | 10 |
| Assembly instruction LADDER:..... | 15 |
| Safety instructions:..... | 17 |
| Instructions on how to jump on the trampoline..... | 20 |
| EU Declaration of Conformity..... | 21 |

Introduction:

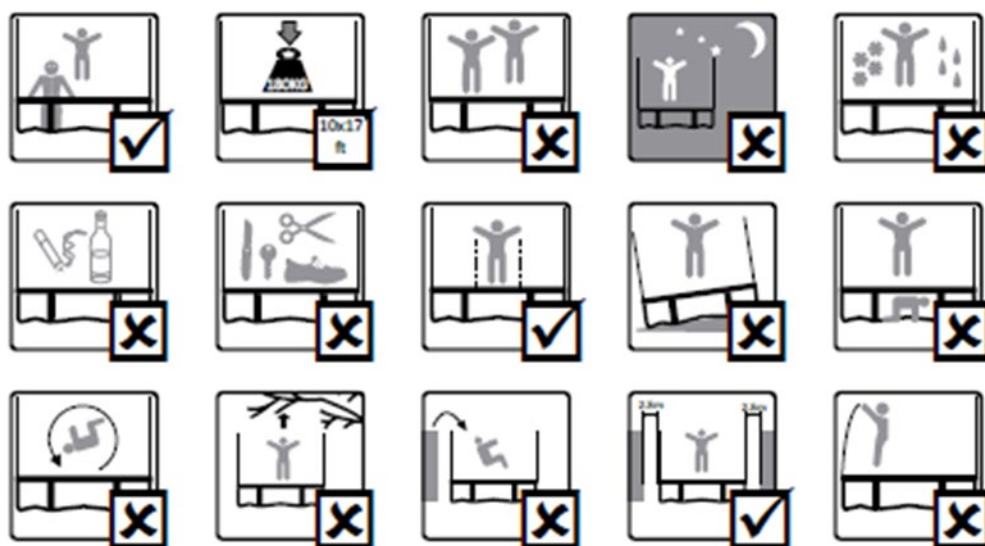

See detailed safety instructions in the back of this manual.

Please read all the safety instructions and the whole assembly guide before use, and retain for future reference. We recommend that two people carry out the assembly of the trampoline. Trampoline shall be assembled by an adult in accordance with the assembly instructions and thereafter checked before first use.

Should you want to move the trampoline, a minimum of two people is required. Lift the trampoline carefully, hold it horizontally and pull the trampoline to the required location. If the trampoline is to be moved far, it should be dismantled and reassembled to make sure that it is not damaged.

If the trampoline is not in use for an extended period, it should be dismantled and packed away. Store in a dry place.



Important information:

Read the entire manual thoroughly before assembly and / or use of this product. Please follow the manual carefully and keep it for future reference.



Important Information: It is important that all products assembled with all types of screws are tensioned two weeks after assembly and every three months to ensure that the product is stable throughout its life.

Content box 1

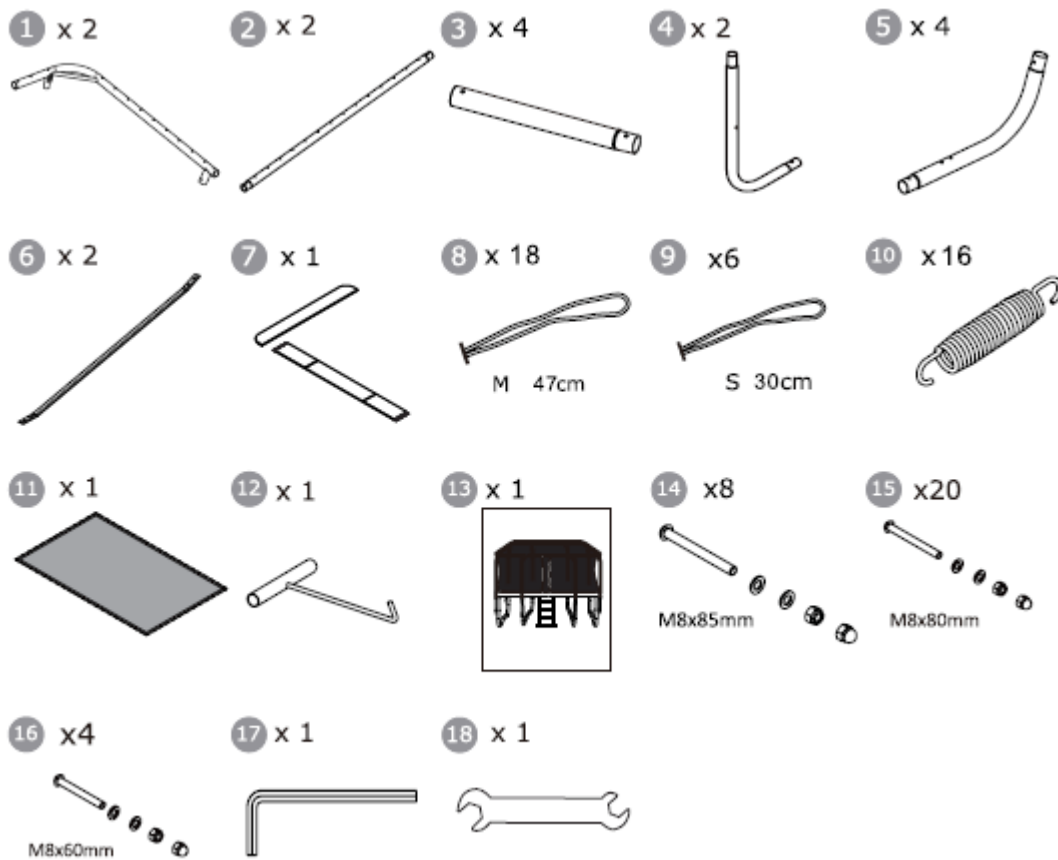

Content box 2

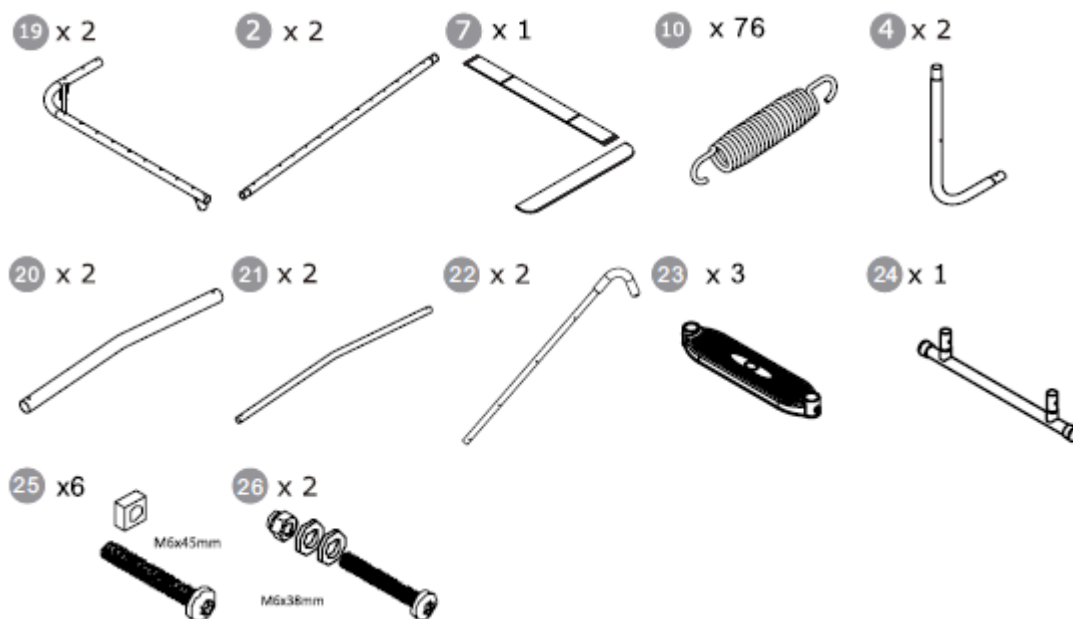

Content box 3

27 x 8



28 x 4



29 x 4



30 x 1



31



x 2

31A



x 6

31B

32



x 2

32A



x 4

32B

33 x 8



6mm

34 x 8



18mm

35 x 8



36 x 8



37 x 8



38 x 4



39 x 8



Assembly instruction, FRAME:
Components:

1 x 2



2 x 4



3 x 4



4 x 4



5 x 4



6 x 2



7 x 1

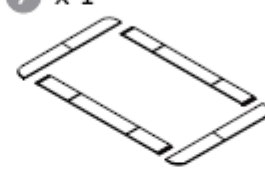

10 x 92



11 x 1

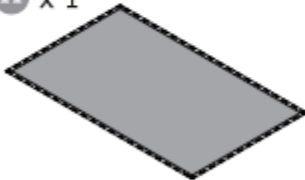

12 x 1



14 x 8

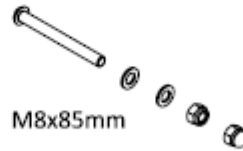

15 x 20

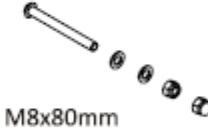

16 x 4



17 x 1



18 x 1



19 x 2



20 x 2



21 x 2



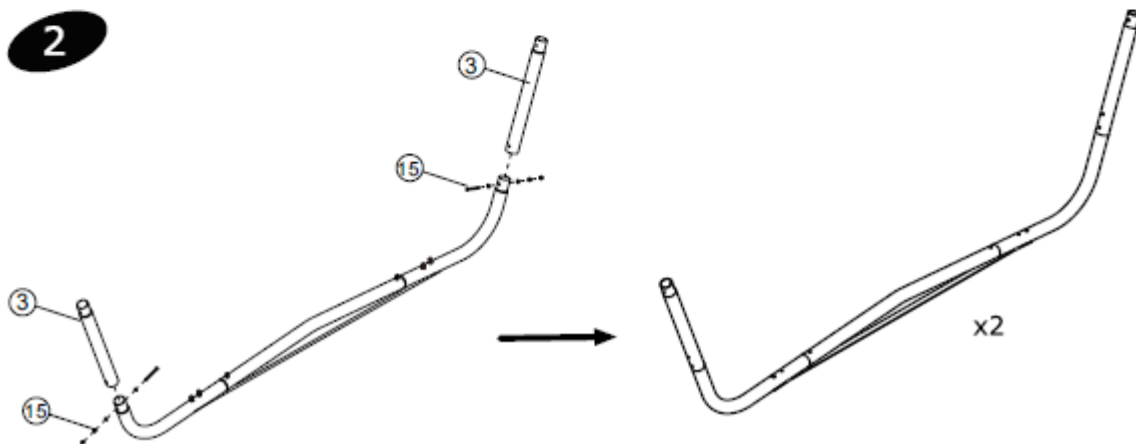
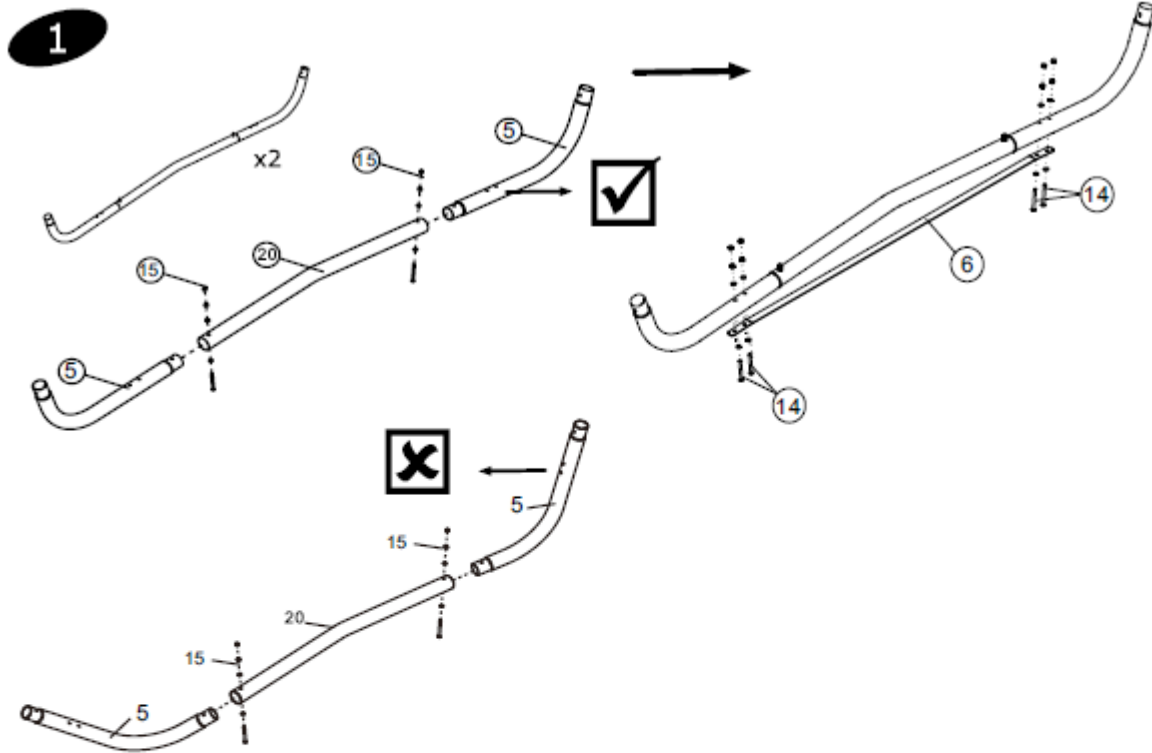

3

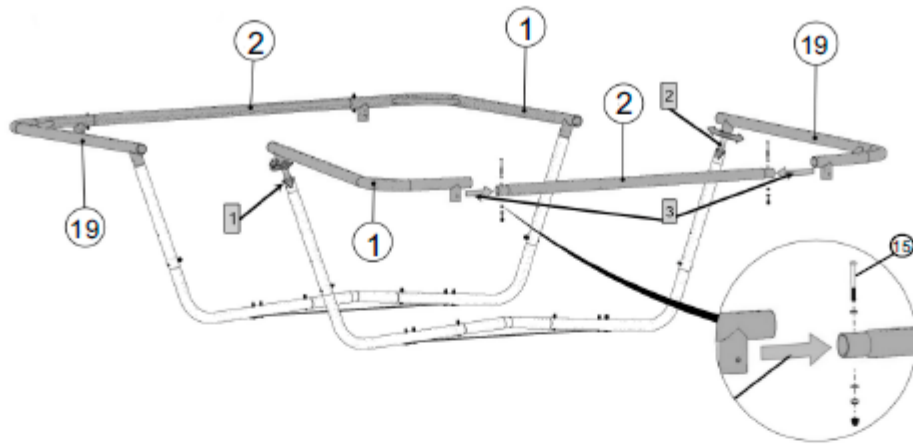

4

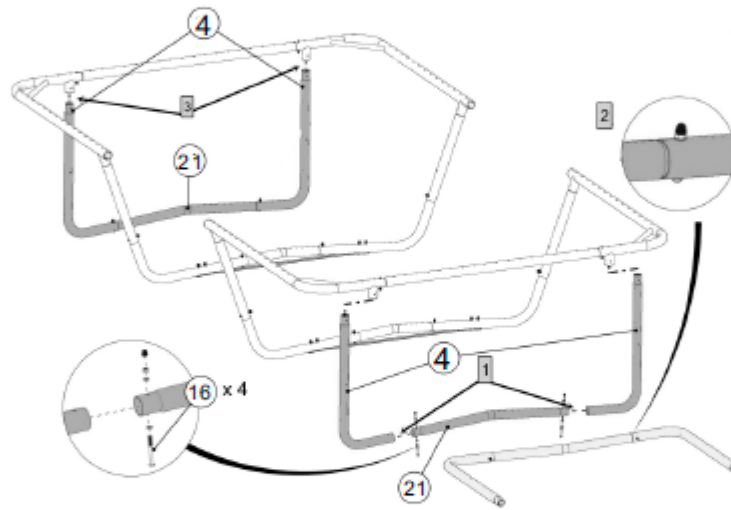

5

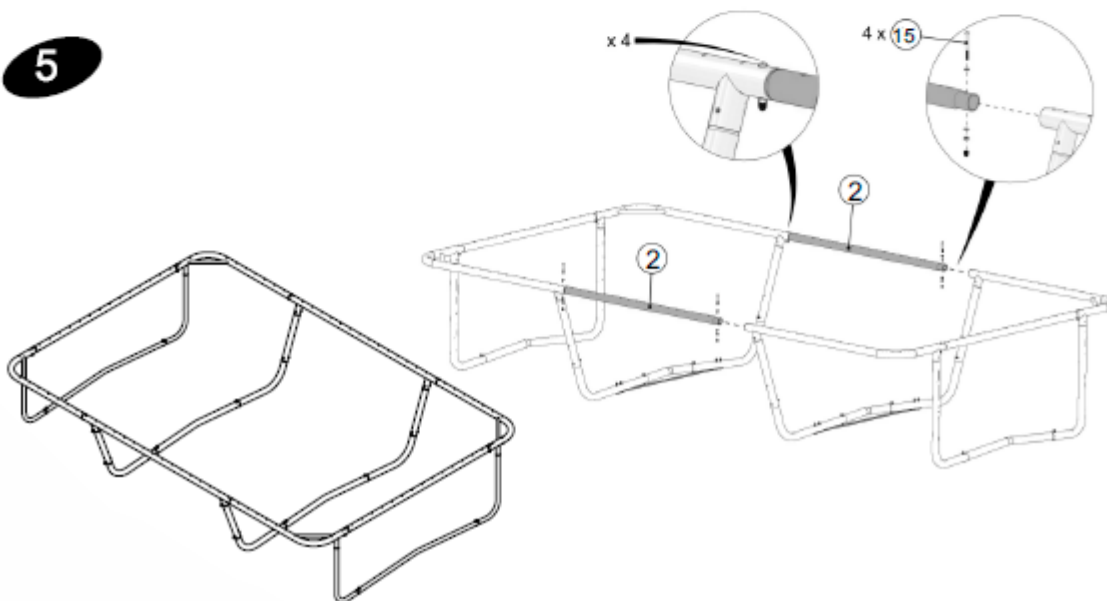

6

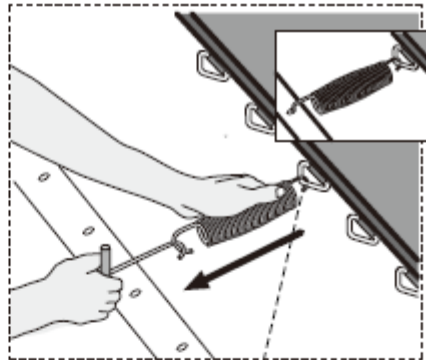
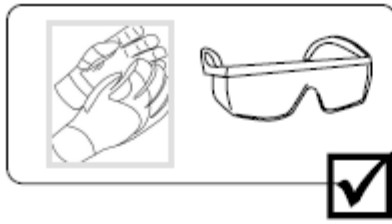

x92

1

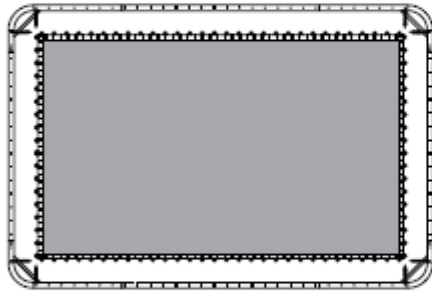

2



3

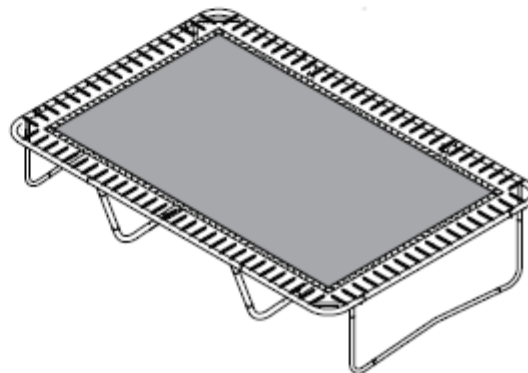

7

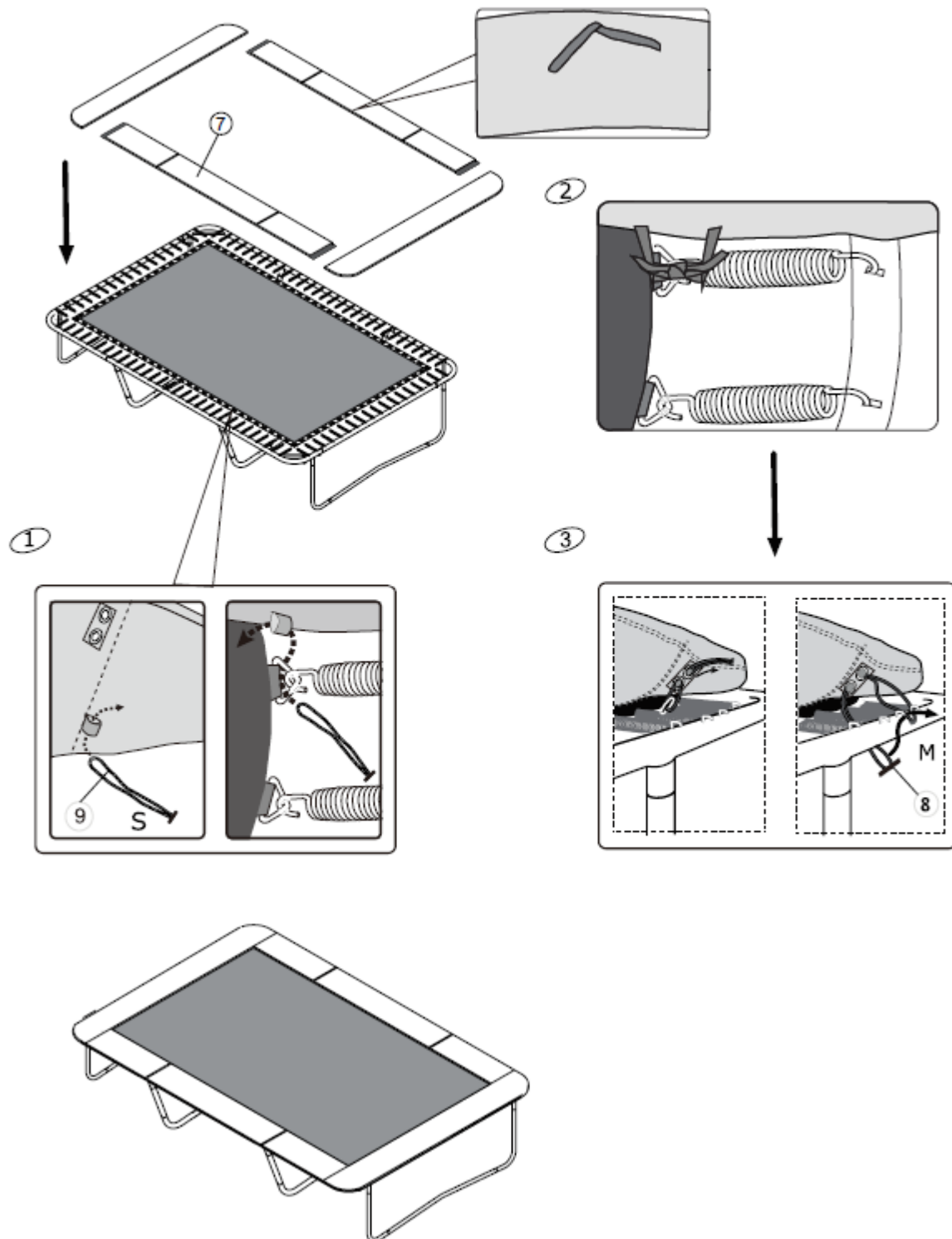

Assembly instruction NET:

27 x 8



28 x 4



29 x 4



30 x 1

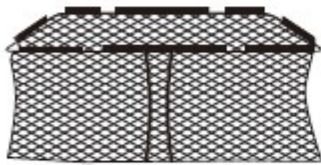

31

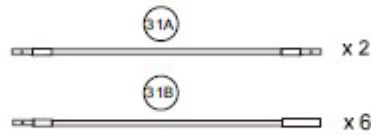

32

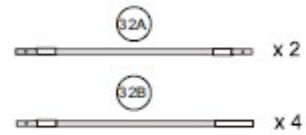

33 x 8

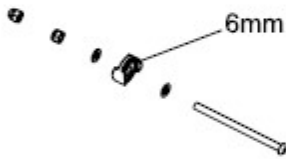

34 x 8

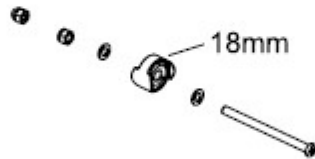

35 x 8



36 x 8



37 x 8



38 x 4

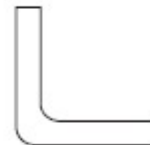

39 x 8



17 x 1



18 x 1





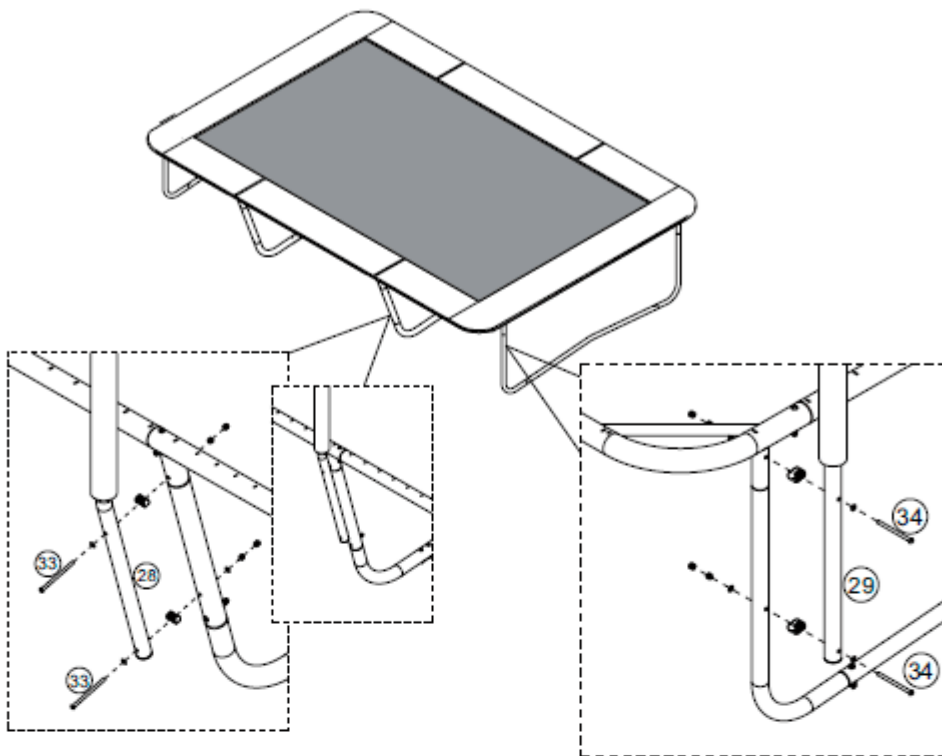

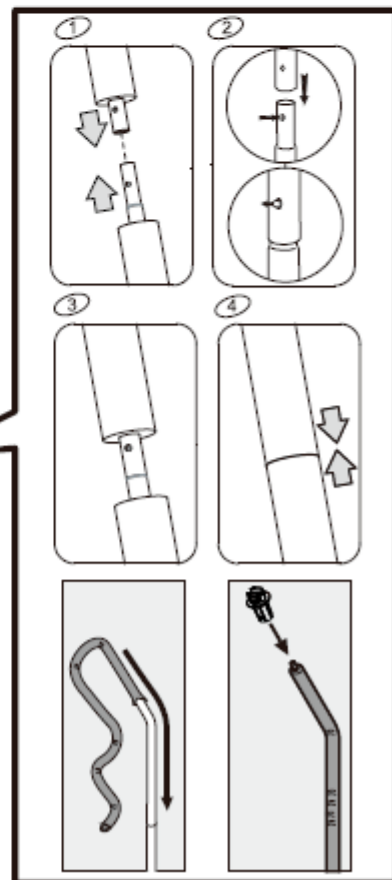
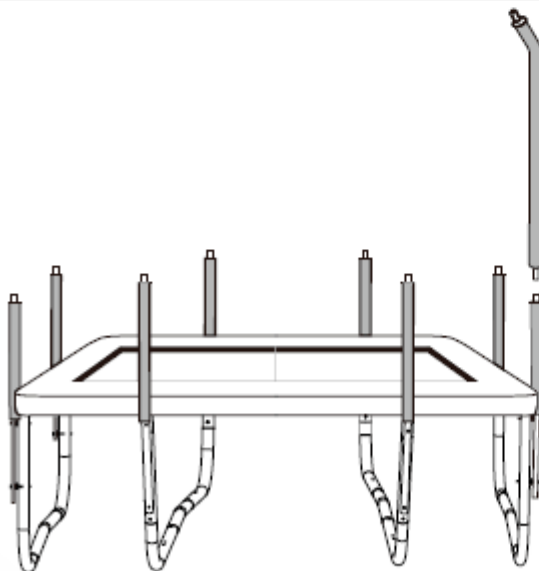

8



9



10

- 31A  x 2 31B  x 4
- 32A  x 2 32B  x 6
- 30  x 1 38  x 4 39  x 8

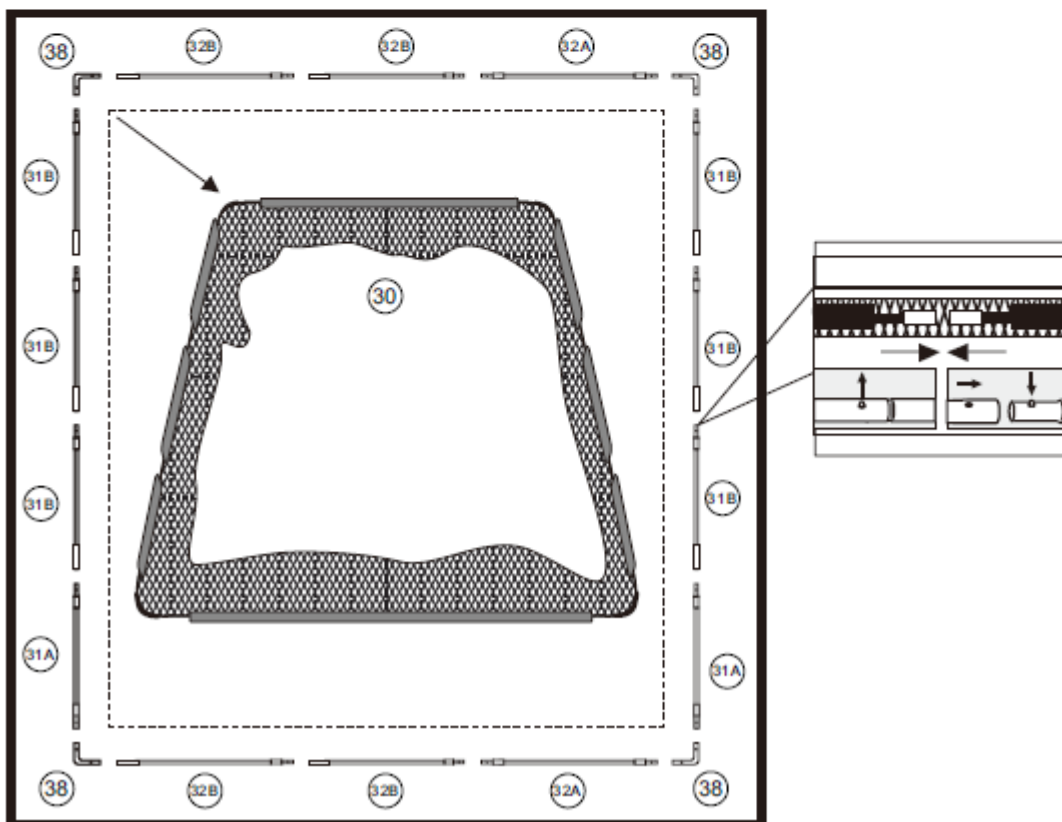
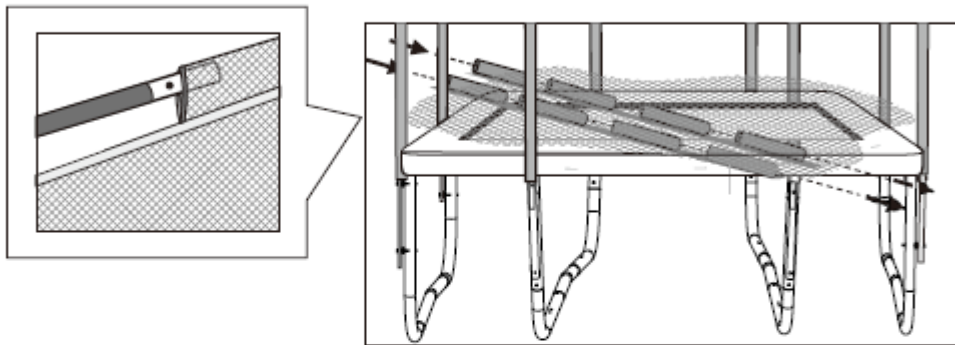

11

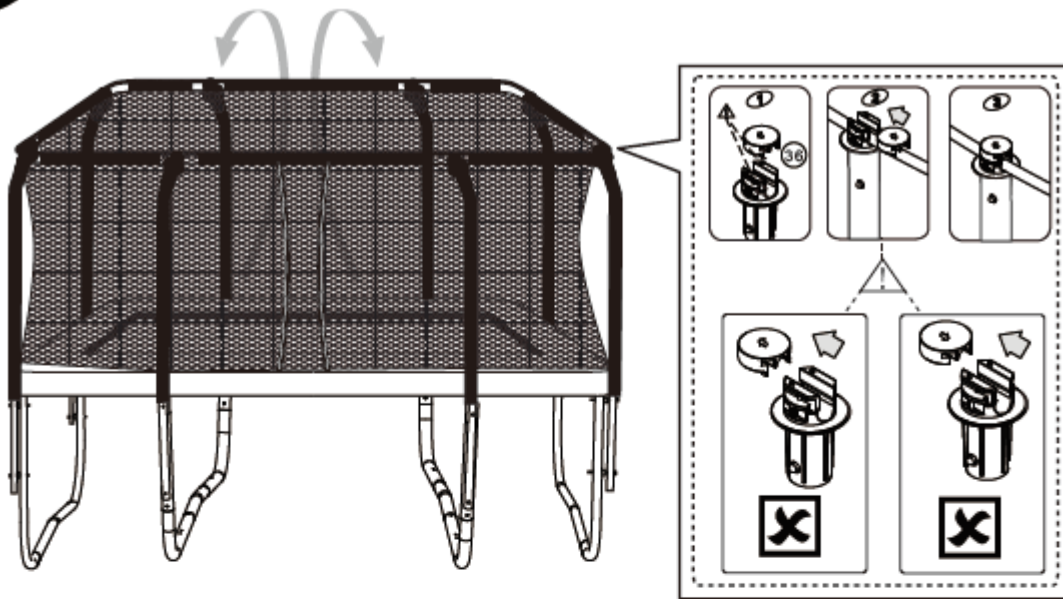

12

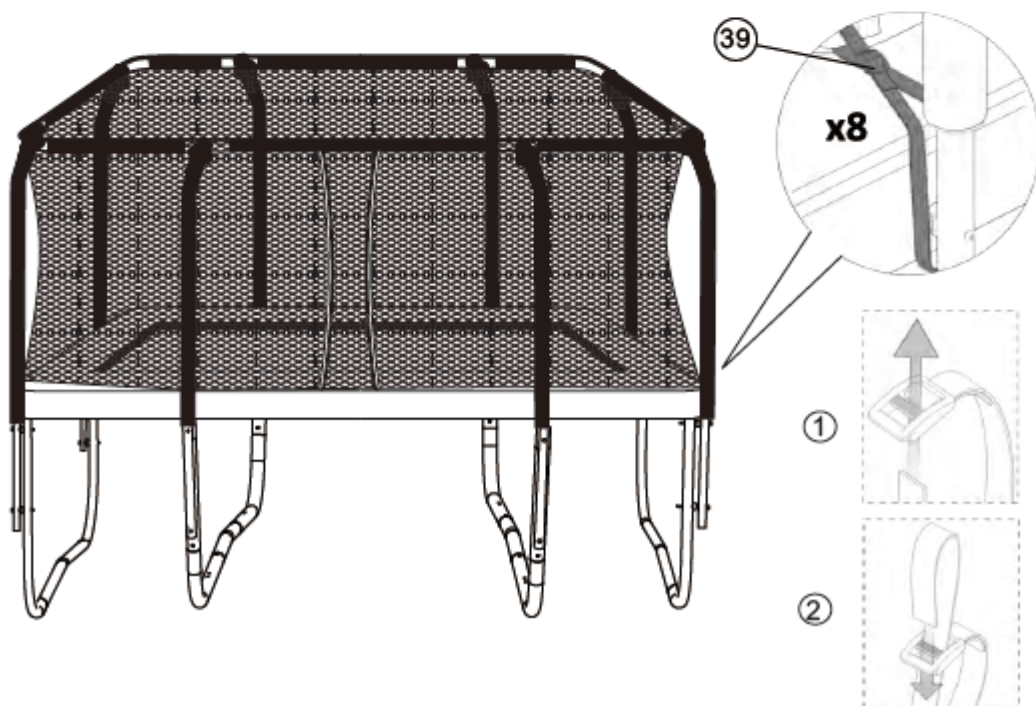

13

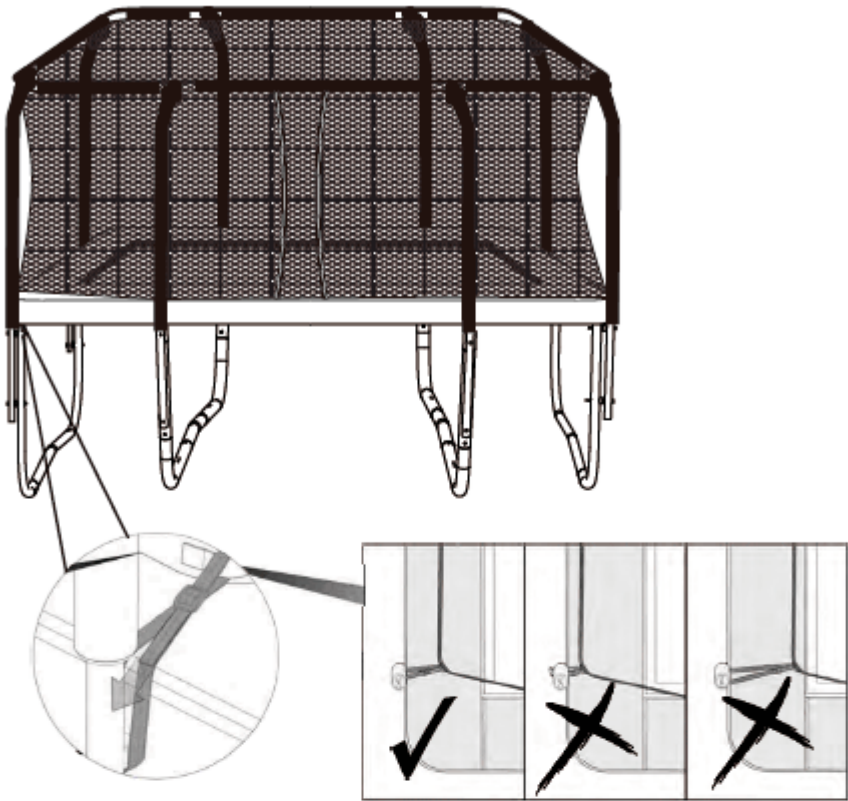

14

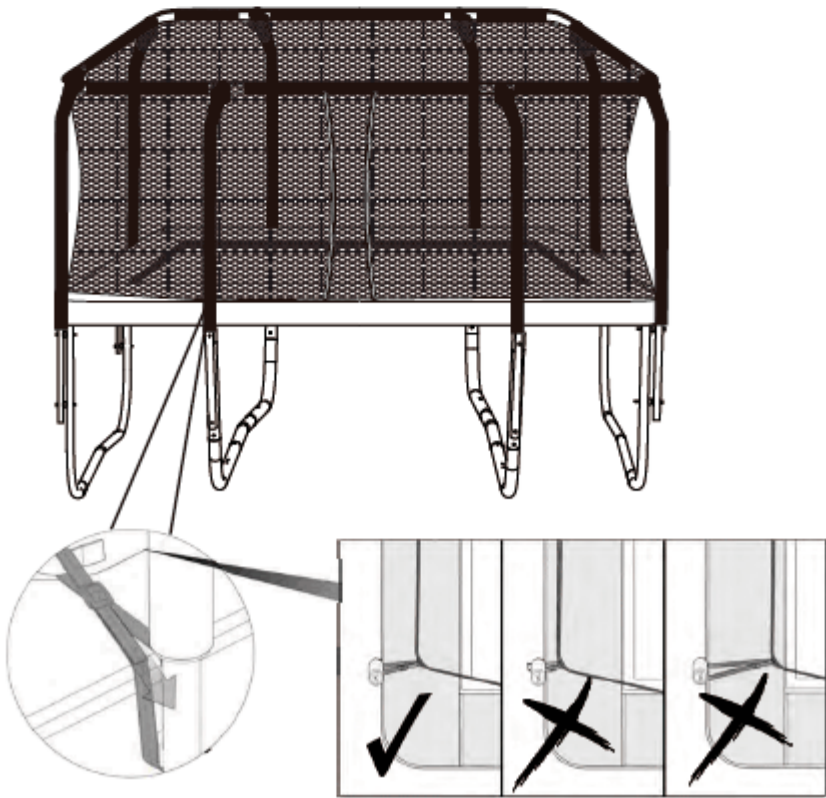

15

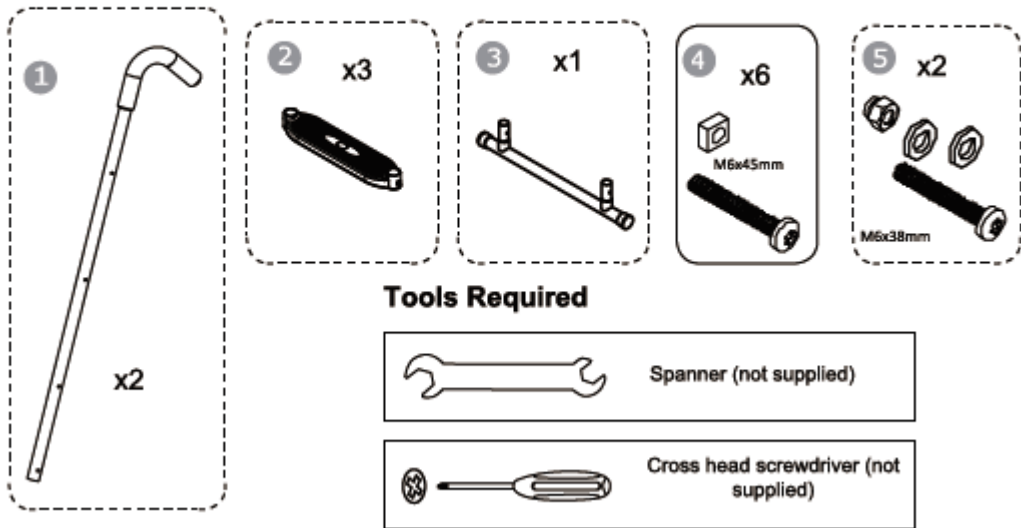

Important information:
 Trampoline and net should be packed away in winter. Make sure all parts are dry and packed securely. Store dry. Always be aware of wear and tear due to weather and wind.

Assembly instruction LADDER:

16

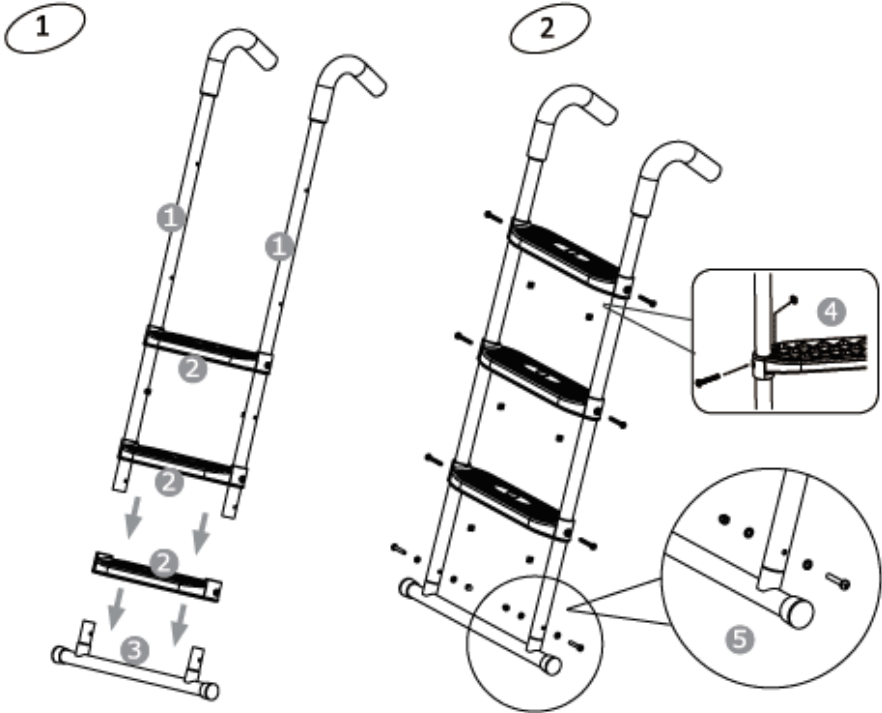

17

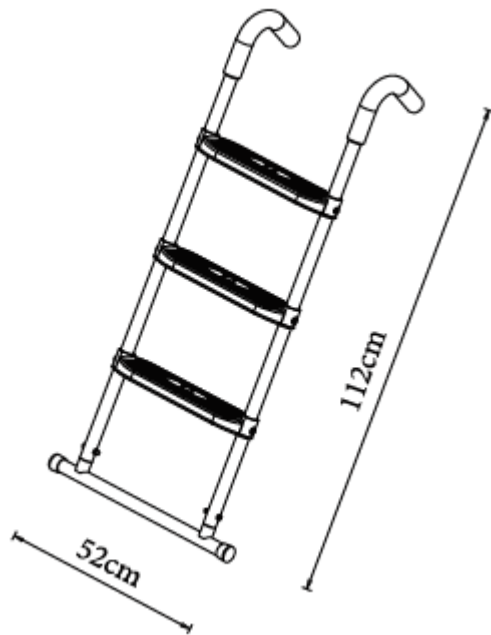

Small parts. Not for children under 3 years



Important information:
It is important that any product which is assembled using any kind of screw is re-tightened 2 weeks after assembly, and once every 3 months – in order to assure stability throughout the lifespan of the product.

18

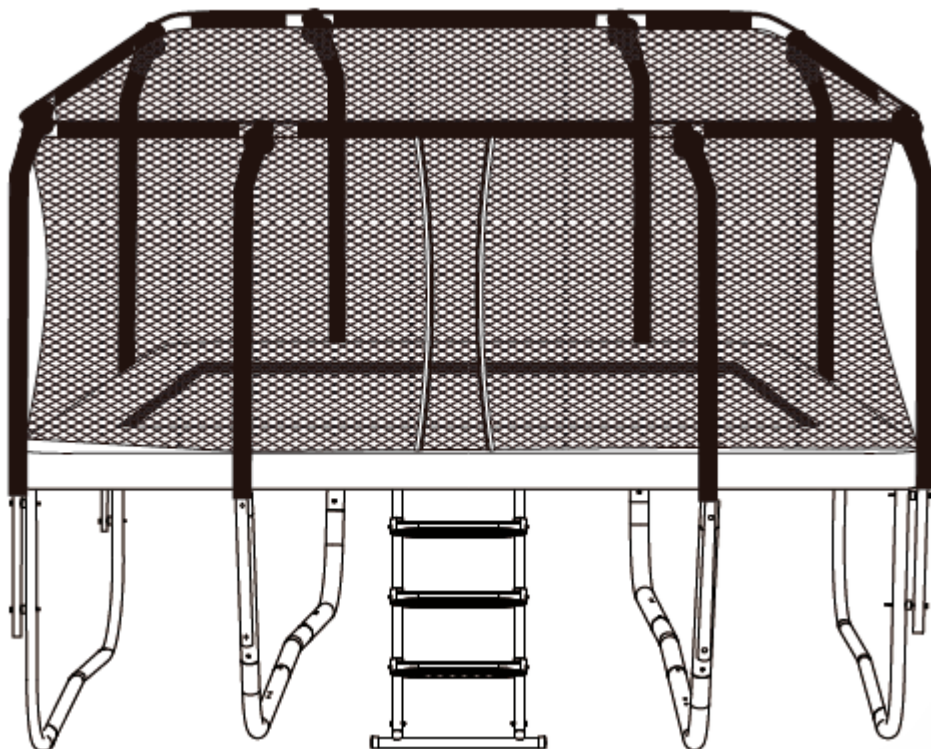

Safety instructions:



Not suitable for children under 3 years due to their inability to use the trampoline correctly.

This trampoline is for domestic use and may only be used outdoors.
Max load 160 KGS.

The owner or person supervising is responsible for ensuring that all users are sufficiently informed about all safety instructions and correct use of the trampoline!



WARNINGS

- Do not use the trampoline without adult, expert supervision.
- No more than one person should use the trampoline at a time. The trampoline is only designed for one person!
- Two people may never use the trampoline at the same time! This increases the risk of injury, including serious injuries such as a broken neck, paralysis, etc.
- Do not perform somersaults! Somersaults increase the risk of landing on your head or neck which may result in serious injuries or even death. Limit the time of continuous usage (make regular stops).
- Jump in the middle of the trampoline pad. Hitting the padded edge of the trampoline may cause injuries as this is not designed to be jumped or stepped on.
- Always be careful when climbing onto the trampoline to avoid getting caught in the springs or hitting the frame.
- Always make sure that the padded edge is fitted correctly and covers the frame and springs to avoid injury. Do not jump down off the trampoline. Climb off carefully to avoid injury.
- All users should be aware of their own limitations. The risk of severe injury must be taken seriously. It is important to bend your knees on landing to achieve the best possible control. Jump up and and in the same spot -this provides the best control. Aim for the middle marking. Gain full control of your jumps before attempting more difficult jumps.
- Do not use the trampoline when you are under the influence of alcohol, medicine or other drugs. This dramatically increases the risk of injury as coordination, judgement and reaction time are affected.
- Do not smoke when using the trampoline.
- Do not use the trampoline if you suffer from high blood pressure.
- Do not use the trampoline if you are pregnant.
- Never jump down onto the trampoline from a roof or other elevations. This increases

- the risk of injury.
- Do not pull yourself up onto the trampoline by the padded edge.
- Do not use the trampoline if it is wet. The trampoline pad becomes slippery and this
- increases the risk of the jumper falling and injuring him/herself.
- Do not use the trampoline in strong winds. This may unbalance the jumper and thereby result in serious injuries.
- Inspect the trampoline for defects before use EVERY time. • Tighten up fittings and
- check regularly that all ties have been tied
- correctly.
- Replace any worn or defective parts. Remedy any defects. Make sure that the trampoline is free of algae, soil, etc.
- Do not use shoes, boots or other footwear on the trampoline.
- Make sure that clothes and pockets do not contain sharp objects when using the
- trampoline.
- Do not allow pets onto the trampoline. Sharp claws can damage the trampoline pad.
- If using a ladder to get on and off the trampoline, please make sure that the trampoline is not used without supervision! Remove the
- ladder, if applicable.
- Do not use the trampoline after dark.
- Make sure the zip on the netting remains closed when the trampoline is in use.
- Remember that the netting is not designed for jumping into to gain more speed or for
- taking off faster!
- Make sure that the hook-and-loop fasteners are closed correctly during use of
- trampoline.
- Check regularly that the netting has been fitted correctly. Tighten up the assembly fittings.
- Inspect the trampoline and the netting for defects before use EVERY time. Tighten up
- fittings and check regularly that all ties have been tied correctly.
- Before season is started maintenance is required.
- Regular maintenance is required. Neglecting regular maintenance can lead to a risk
- for users.
- Check all nuts and bolts for tightness and tighten when required.
- Check that all spring-loaded (pit pin) joints are still intact and cannot become dislodged during play.
- Only one user at a time due to collision hazard.
- No Somersaults are allowed.
- Adult supervision required.
- Check all coverings for bolts and sharp edges and replace when required.
- Modifications made by consumer to the original trampoline (e.g. the adding of an
- accessory) Shall be carried out according to the instructions of the manufacturer.



WARNINGS

Location of the trampoline:

- There must be a minimum headroom above the trampoline of 7.3 metres, i.e. this area should be free of objects of any kind.
- The trampoline must be placed on a flat and level surface.
- The surface must not be concrete, tiles or asphalt.
- No objects must be placed under the trampoline.
- The trampoline must be located at a suitable distance (minimum 2.5 m) from electric cables, swimming pools, fences, trees and branches, climbing frames and other objects.

Maintenance:

Clean the trampoline pad using a damp cloth to remove any algae, dirt, etc. Then wipe with a dry cloth. Do not use the trampoline before it is completely dry. Do not use cleaning agents or other chemicals to clean the product. Tighten all fittings regularly, and make sure the mat is correctly fitted.

Further information:

We recommend securing the trampoline in strong winds. Tie the trampoline down with ropes attached to the trampoline frame. Tie the trampoline down in a minimum of three places distributed evenly across the trampoline frame. Do not secure the legs as these may become misaligned and ruin the trampoline. Dismantle or remove the trampoline completely, if required. It may result in great danger if the trampoline is not secured in strong winds.





WARNINGS

- Safety net needs to be replaced after 2 years.
- Before jumping you need to close safety net.
- Forbidden to eat during jumping.
- The trampoline is not intended to be dug into the ground.
- In certain countries during winter, the snow load and very low temperatures can damage the trampoline. It is recommended to remove the snow, and store the mat and the enclosure indoor.

Instructions on how to jump on the trampoline



EU Declaration of Conformity

| | | |
|---|--|---|
| EU DECLARATION OF CONFORMITY | |  |
| EU – importer: | P. Lindberg A/S Sdr. Ringvej 1 DK-6600 Vejen Phone: +45 70212626 E-mail: salg@p-lindberg.dk CVR: 25903110 www.p-lindberg.dk | |
| Hereby declare that the following machine: | Square trampoline 512 x 305 cm. PL item no. 9062850 | |
| Type / model: | TATR-1017BR | |
| Complies with the following directives: | 2009/48/EC | |
| Applied standards and norms: | EN 71-1:2014 + A1:2018 EN 71-2:2011+A1:2014 EN 71-14:2018 EN 71-3:2019 | |
| Date and signature: | Vejen d.16-11-2020 P. Lindberg A/S  Erik T Lauritsen Direktør | |
| | |  |

We retain the right to change the technical parameters and specifications of this product without prior notification.